

# Signal-Flow-Graph Identities for Structural Transformations in Multirate Systems

Alexandra Groth\* and Heinz G. Göckler\*†

**Abstract** — Signal-flow-graph (SFG) transformations by means of identities are frequently used to obtain efficient structures. In contrast to time-domain approaches these transformations are graphical and therefore easier to handle. In this paper well-known noble identities [2] for multirate signal processing are revisited and extended. To this end up- and downsamplers with arbitrary integer phase shifts are introduced. As an application, a novel  $z$ -domain approach to efficient fractional sample rate conversion is given.

## 1 Introduction

A signal flow graph (SFG) symbolically represents a particular implementation of an algorithm, and depicts the inherent signal flows in detail. Hence, efficient structures with low computational load can be obtained by SFG manipulations. To this end, well-known identities [1,2] are widely exploited.

In multirate signal processing so-called noble identities [2] are frequently applied. Here, up- and downsampling is restricted to zero phase shift. As a consequence, e.g. reversing the order of up-/downsamplers and delays is limited to  $L$ - or  $M$ -fold multiples of the unit delay. Hence, in the general case, delay interchanging is impossible or leads to an increased group delay due to the necessity of additional delay.

In contrast to previous publications, the aim of this contribution is to revisit and extend identities in which arbitrary delays are involved by overcoming the aforementioned restrictions. For this purpose down- [3] and upsamplers are generalized by the introduction of arbitrary phase shifts. As a consequence, no additional delay is required in the course of transformation and the group delay remains unchanged.

As an example, the derivation of efficient fractional sample rate conversion (FSRC) is revisited. By exploiting the well-known noble identities [2] only block-processing structures with increased group delay can be deduced [4-5]. In contrast, a sample-by-sample approach to FSRC without additional group delay has so far been derived in

the time-domain only [6]. Hence, by applying the newly introduced multirate identities, a  $z$ -domain representation of a sample-by-sample FSRC is developed.

Subsequently, we first introduce the required novel identities in section 2 in order to derive the  $z$ -domain approach to fractional sample rate conversion in section 3.

## 2 Novel Identities

In previous publications it is generally assumed that up- and downsamplers use a phase shift of zero. In order to allow arbitrary sampling time instants, time shifts  $\lambda T_o \in \{0, \dots, L-1\}T_o$  (upsampler) and  $\mu T_i \in \{0, \dots, M-1\}T_i$  (downsampler [3]) are introduced. In the SFG representation this is indicated by a dashed line with assigned time shift (cf., e.g., Fig. 1 left with  $\lambda = 0$ ). Hence, in time domain this novel generalized upsampler is defined by

$$y(mT_o) = \begin{cases} x(\frac{m}{L}T_i) & m = nL + \lambda, m \in \mathbb{Z} \\ 0 & \text{otherwise,} \end{cases} \quad (1)$$

and the downsampler by

$$y(mT_o + \frac{\mu}{M}T_o) = x(mMT_i + \mu T_i) \quad . \quad (2)$$

By permitting arbitrary time shifts the novel identities can be derived. This concerns all identities with delays involved. To this end, we *i*) have a closer look at up- and downsampling with shifted sample instants (identity 1), *ii*) consider order reversal of arbitrary delay and up-/downsampling (identity 2) *iii*) and of up- and downsamplers with intermediate arbitrary delay (identity 3).

### Identity 1: Shift of sampling instant

The identities referring to the shift of sampling instant are depicted in Fig. 1 whereby, both for up- and downsampling, two options are given.

The correctness is, for instance, proven for the upsampler (option a) by demonstrating that the output signals  $y(mT_o)$  of both structures are identical. As already known  $y(mT_o)$  of the original structure (Fig. 1 left) is given by Eq. (1) with  $\lambda = 0$ . However, the output signal of the modified structure (Fig. 1a, top right) can be obtained by time

\*Ruhr-Universität Bochum, Digital Signal Processing Group, Universitätsstr. 150, D-44780 Bochum, Germany. E-mail: groth@nt.ruhr-uni-bochum.de, Tel: +49-234-3222805, Fax: +49-234-3214100.

†This work was supported by Deutsche Forschungsgemeinschaft under contract GO 849/1-3.

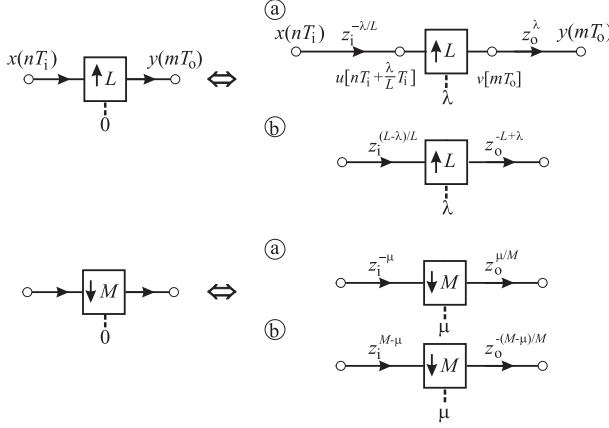

Figure 1: Change of sampling instant (Two options).

shifting the input signal  $x(nT_i)$  according to

$$u(nT_i + \frac{\lambda}{L}T_i) = x(nT_i) \quad . \quad (3)$$

In compliance with Eq. (1) upsampling of  $u(nT_i + \frac{\lambda}{L}T_i)$  with time shift of  $\frac{\lambda}{L}T_i = \lambda T_o$  leads to

$$\begin{aligned} v(mT_o) &= \begin{cases} u(\frac{m}{L}T_i) & m = nL + \lambda, m \in \mathbb{Z} \\ 0 & \text{otherwise} \end{cases} \quad (4) \\ &= \begin{cases} x(\frac{m-\lambda}{L}T_i) & m = nL + \lambda, m \in \mathbb{Z} \\ 0 & \text{otherwise.} \end{cases} \end{aligned}$$

Finally  $v(mT_o)$  is anti-delayed according to

$$\begin{aligned} y(mT_o) &= v(mT_o + \lambda T_o) \quad (5) \\ &= \begin{cases} x(\frac{m}{L}T_i) & m = nL + \lambda - \lambda = nL, m \in \mathbb{Z} \\ 0 & \text{otherwise.} \end{cases} \end{aligned}$$

As a result we obtain  $y(mT_o)$  which confirms Eq. (1) with  $\lambda = 0$ .

Note that  $z_i^{-\lambda/L}$ ,  $z_o^{-\mu/M}$  are only required as shimming delays and, hence, do not represent a fractional delay.

### Identity 2: Order reversal of up- or downsampler and arbitrary delay

By applying the well-known identities [2] order reversal of up- or downsamplers and delays is restricted to  $z_o^{-\alpha} = z_o^{-\beta L}$  or  $z_i^{-\alpha} = z_i^{-\beta M}$  ( $\beta \in \mathbb{N}$ ). However, the novel identities (Fig. 2) overcome these restrictions.

The proof of Fig. 2 is self-evident and can be conducted by applying identity 1 and eliminating the anti-delay by combining it with the delay  $z_o^{-\alpha}$ .

Again,  $z_i^{-\frac{\alpha}{L}}$ ,  $z_o^{-\frac{\alpha}{M}}$  represent shimming delays.

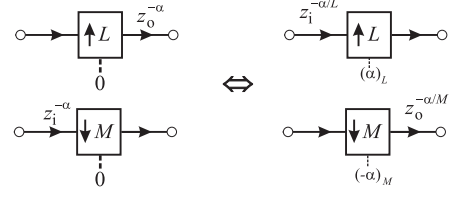

Figure 2: Order reversal of up- or downsampler with arbitrary delay ( $(\alpha)_N = \alpha$  modulo  $N$ ).

### Identity 3: Order reversal of up- and downsampler with intermediate delay

Finally a novel result for the order reversal of up- and downsampler with an arbitrary intermediate delay is presented in Fig. 3, whereby  $\mu$  and  $\lambda$  result from the linear diophantine equation

$$M\lambda - L\mu = \alpha \quad (6)$$

with  $\alpha \in \{0, \dots, \min(M-1, L-1)\}^1$ ,  $\mu \in \{0, \dots, M-1\}$ ,  $\lambda \in \{0, \dots, L-1\}^2$ ,  $L$  and  $M$  coprime. The merit of the novel identity in contrast to the well-known one<sup>3</sup> is the unchanged group delay of the resulting structure.

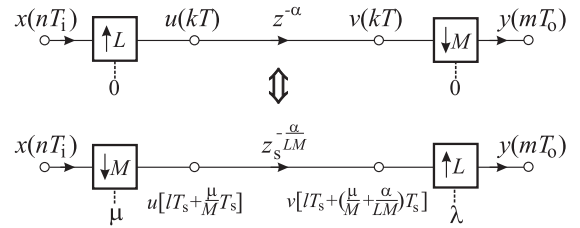

Figure 3: Order reversal of up-and downsampler with intermediate delay.

For the prove of this identity it is demonstrated that the output signal of the original structure (Fig. 3, top) matches that of the modified structure (Fig. 3, bottom).

### OUTPUT SIGNAL OF ORIGINAL STRUCTURE

The  $L$ -fold upsampler takes the input signal  $x(nT_i)$  and produces an output sequence

$$u(kT) = \begin{cases} x(\frac{k}{L}T_i) & \forall k = nL, n \in \mathbb{Z} \\ 0 & \text{otherwise.} \end{cases} \quad (7)$$

<sup>1</sup>For all  $\alpha > \min(M-1, L-1)$  an identity can easily be derived by combining identity 2 and 3.

<sup>2</sup>Proof for  $\mu \in \{0, \dots, M-1\}$ ,  $\lambda \in \{0, \dots, L-1\}$  cf. [5]

<sup>3</sup>Partitioning of the intermediate delay in an  $M$ -fold delay and and  $L$ -fold anti-delay or visa versa before reversing the order of up- and downsampler

By delaying  $u(kT)$   $\alpha$  time units, we obtain

$$\begin{aligned} v(kT) &= u[(k - \alpha)T] \\ &= \begin{cases} x(\frac{k-\alpha}{L}T_i) & \forall k = nL + \alpha, n \in \mathbb{Z} \\ 0 & \text{otherwise.} \end{cases} \end{aligned} \quad (8)$$

Finally  $v(kT)$  is decimated by an  $M$ -fold downsampler leading to the overall output signal

$$\begin{aligned} y(mT_o) &= v(mMT) \\ &= \begin{cases} x(\frac{mM-\alpha}{L}T_i) & \forall mM = nL + \alpha, n \in \mathbb{Z} \\ 0 & \text{otherwise.} \end{cases} \end{aligned} \quad (9)$$

#### OUTPUT SIGNAL OF THE MODIFIED STRUCTURE

In the modified structure (Fig.3, bottom) the  $M$ -fold downsampler takes the input signal  $x(nT_i)$  at time instants  $(lM + \mu)T_i$  with  $l \in \mathbb{Z}$  and produces an output sequence (Eq. (2))

$$u(lT_s + \frac{\mu}{M}T_s) = x(lMT_i + \mu T_i), \quad (10)$$

which is only defined at time instants  $(l + \frac{\mu}{M})T_s$ . Interpreting  $z_s^{-\frac{\mu}{LM}}$  as a shimming delay leads to the intermediate signal

$$\begin{aligned} v[lT_s + (\frac{\mu}{M} + \frac{\alpha}{LM})T_s] &= u(lT_s + \frac{\mu}{M}T_s) \\ &= x(lMT_i + \mu T_i), \end{aligned} \quad (11)$$

which differs from  $u(lT_s + \frac{\mu}{M}T_s)$  only in the time instant at which it is available. By introducing  $M\lambda - L\mu = \alpha$  (Eq. (6)) we obtain

$$v(lT_s + \frac{\lambda}{L}T_s) = x(lMT_i + \mu T_i). \quad (12)$$

Finally, we get the overall output signal

$$\begin{aligned} y(mT_o) &= \begin{cases} v(\frac{m}{L}T_s) & \forall m = lL + \lambda, l \in \mathbb{Z} \\ 0 & \text{otherwise} \end{cases} \\ &= \begin{cases} x[\frac{m-\lambda}{L}MT_i + \mu T_i] & \forall m = \frac{n-\mu}{M}L + \lambda, \\ & \frac{n-\mu}{M} \in \mathbb{Z} \\ 0 & \text{otherwise} \end{cases} \end{aligned} \quad (13)$$

by an  $L$ -fold upsampling at time instants  $(lL + \lambda)T_o$  with  $l \in \mathbb{Z}$  and  $\lambda \in \{0, \dots, L - 1\}$  (Eq. (1)). By rearranging the offset and exploiting Eq. (6) we obtain the same output signal

$$\begin{aligned} y(mT_o) &= \begin{cases} x[\frac{mM}{L}T_i - (\frac{\lambda M}{L} - \mu)T_i] & \forall (\text{see (13)}) \\ 0 & \text{otherwise} \end{cases} \\ &= \begin{cases} x[\frac{mM}{L}T_i - \frac{\alpha}{L}T_i] & \forall mM = nL + \alpha, \\ & n \in \mathbb{Z} \\ 0 & \text{otherwise} \end{cases} \end{aligned}$$

as that of the original structure. q.e.d.

#### Other Identities

The order reversal of multiplications and additions with up- and downsamplers is obvious and, hence, not considered here: Original phase shift remains, interchange is possible without restrictions.

### 3 Efficient sample-by-sample FSRC

The system theoretic approach to FSRC is a cascade connection of an  $L$ -fold upsampler, a filter  $H(z)$  and an  $M$ -fold downsampler (Fig.4). As a consequence, all filter operations have to be performed at the highest rate, which is related to the system input rate  $f_i$  by  $Lf_i$ .

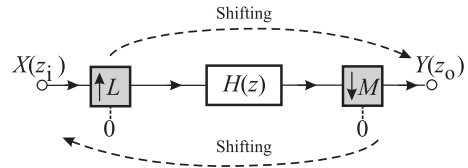

Figure 4: Fractional sample rate converter (FSRC).

As already indicated [4-5], significant savings in computational expenditure can be obtained by reversing the order of  $L$ -fold up- and  $M$ -fold downsampler. As a result, we obtain a system operating at a subnyquist sample rate  $f_s = f_i/M$  (Fig. 8). To this end, the novel identities which are derived in the previous section are exploited.

#### Step 1: Polyphase Decomposition of $H(z)$

In the derivation process we start with an  $LM$ -branch polyphase decomposition of the FSRC filter (Fig. 5, [5]) according to

$$H(z) = \sum_{\nu=0}^{LM-1} z^{-\nu} H_{\nu}(z^{LM}) \quad (14)$$

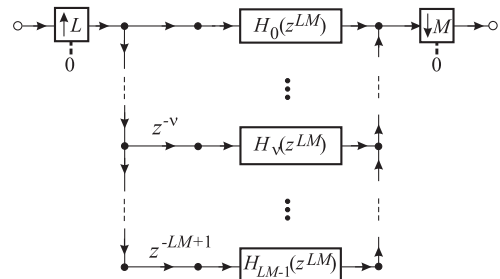

Figure 5: Polyphase decomposition of  $H(z)$ .

## Step 2: Order reversal of up- and downsampler

In the intermediate step up- and downsampler are shifted into each branch of the polyphase filter, whereby the order of branch filters  $H_\nu(z^{LM})$  and subsequent  $M$ -fold upsampler is interchanged according to [2]. Thus, we obtain a cascade connection of  $L$ -fold upsampler, delay  $z^{-\nu}$  and  $M$ -fold downsampler (Fig. 6).

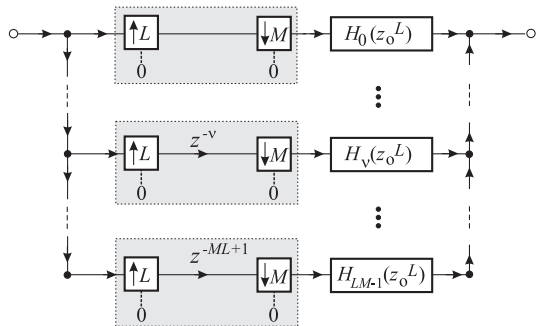

Figure 6: Order reversal of downsampler and branch filters.

Exploiting the novel identity 3 (Fig. 3) allows us to interchange the order of these building blocks without any increase in group delay (cf. with [5]). Eventually the order of upsamplers and branch filters is reversed (see: Other Identities). The result is depicted in Fig. 7 including shimming delays.

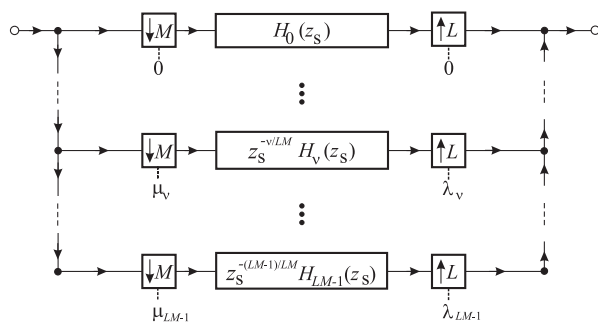

Figure 7: Order reversal of up- and downsampler according to Fig. 3.

## Step 3: Rearrangement of Branches

Finally, a pooling of branches with up- or downsampler of identical phase shift is required in order to minimize the total number of hardware elements. As a result, we obtain the desired efficient sample-by-sample FSRC consisting of an input and output commutator and an  $L \times M$  MIMO (Multiple Input Multiple Output) system (Fig. 8).

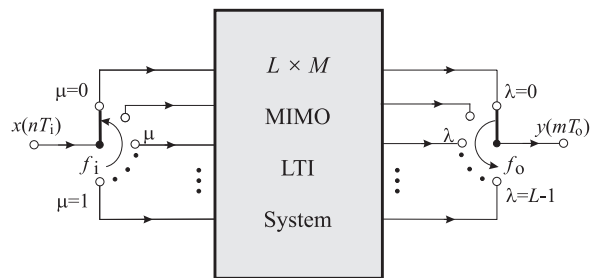

Figure 8: Desired efficient structure.

As already indicated, the above result can also be obtained by a time-domain polyphase decomposition [6] confirming the  $z$ -domain outcome (Fig. 8). Note that, in contrast to a block-processing approach, we achieve a reduction of group delay by  $(ML - L - M + 1)T$  corresponding to  $z^{-(ML-L-M+1)}$ .

## 4 Conclusion

In this paper new identities for up- and downsamplers in connection with delays are presented. To this end, samplers with arbitrary integer time shift are introduced. As an application, a new systematic and rigorous derivation of efficient sample-by-sample fractional sample rate conversion is given.

## References

- [1] H.W. Schüßler, *Digitale Signalverarbeitung 1, Analyse diskreter Signale und Systeme*, Springer Verlag, Berlin, 1994.
- [2] P.P. Vaidyanathan, *Multirate Systems and Filter Banks*, Prentice Hall Signal Processing Series, 1993.
- [3] T. Leikel, *Entwurf und Realisierung diskreter Filterbänke*, Ph.D. Thesis, Lehrstuhl für Nachrichtentechnik, Ruhr-Universität Bochum, 1993.
- [4] C.C. Hsiao, *Polyphase Filter Matrix for Rational Sampling Rate Conversions*, ICASSP '87, Dallas, 1987, pp. 2173-2176.
- [5] A. Groth, H.G. Göckler, *Efficient Minimum Group Delay Block Processing Approach to Fractional Sample Rate Conversion*, ISCAS '01, Sydney, Australia, May 2001.
- [6] W.H. Yim, F.P. Coakley, B.G. Evans, *Extended Polyphase Structures for Multirate DSP*, IEE Proc.-F, Vol. 139, No. 4, Aug. 1992, pp.273-277.