



**Aalto University**  
School of Science  
and Technology

Faculty of Electronics, Communications and Automation  
Department of Communications and Networking

Ankit Bhamri

## Distributed Coding and Modulation for 2-hop Communication via Relays

Master's Thesis submitted in partial fulfillment of the requirements for the degree of  
Master of Science in Technology

Espoo, 15<sup>th</sup> October, 2010

Supervisor:	Prof. Jyri Hämäläinen
Instructors:	Prof. Raymond Knopp, Eurecom, France
	Dr. Florian Kaltenberger, Eurecom, France

<b>Author:</b>	Ankit Bhamri	
<b>Title:</b>	Distributed Coding and Modulation for 2-hop Communication via Relays	
<b>Date:</b>	15 <sup>th</sup> October 2010	<b>Number of Pages: 80</b>
<b>Department:</b>	Department of Communications and Networking	
<b>Professorship:</b>	S 72 Communications Engineering	
<b>Supervisor:</b>	Professor Jyri Hämäläinen	
<b>Instructors:</b>	Professor Raymond Knopp Dr. Florian Kaltenberger	
<p>The past few decades have seen tremendous growth in the field of wireless communication systems. At this juncture, just before the advent of the 4<sup>th</sup> Generation of mobile standards, the question asked is how to improve the system in terms of coverage, capacity and reliability for the cell-edge users in a cellular network. Providing answers to this question could result in a significant improvement in the average throughput of the cell.</p> <p>The main purpose of the thesis work is therefore to implement Cooperative Communication via Distributed System of Relays. This concept is derived from the combination of relaying technology and multiple antenna techniques used in MIMO systems. During this thesis work, two transmit diversity schemes: the Delay Diversity Scheme and the Distributed Alamouti Scheme are developed on a 3GPP LTE compliant platform described as the OpenAir Interface. The ultimate objective is basically to improve the system performance by exploiting macro-diversity gains obtained as a result of these schemes. In the process of this development, numerous challenging tasks are provided with efficient solutions and have been implemented. Moreover, the last but the most crucial task of the thesis is to develop an entirely new HARQ protocol for a distributed system of relays.</p> <p>The work has been carried out at Eurecom, France as an initial step to implement the aforementioned schemes on a real-time network.</p>		
<b>Keywords:</b>	3GPP, Cooperative Communication, Delay Diversity, Distributed Alamouti, HARQ, Macro-diversity, MIMO, OpenAir Interface.	

# *Acknowledgements*

To begin with, I would like to extend my sincere gratitude to Professor Raymond Knopp at Eurecom, France for providing me with the opportunity of coming to France for working on this exciting project as a part of the OpenAir Interface development team. During the entire course of this thesis work, one more person I am extremely indebted to is Florian Kaltenberger, who was always there to patiently guide me through every phase of the work and help me exploit various possibilities in my work. Also, it gives me immense pleasure to thank Professor Jyri Hämäläinen for providing me the freedom to work on an international project and giving ample guidance regarding all the issues I faced during the last six months.

Furthermore, I appreciate William Martin, the faculty's language support specialist for his efforts in revising the final draft.

Last, but definitely not the least, I am highly obliged to Jenni Tulensalo for patiently and swiftly handling the administrative work required to make it possible for me to work on my thesis in France.

**Espoo, 15<sup>th</sup> October 2010**

**Ankit Bhamri**

# Contents

<b>Abstract</b>	<b>i</b>
<b>Acknowledgements</b>	<b>ii</b>
<b>List of Figures</b>	<b>v</b>
<b>List of Tables</b>	<b>vii</b>
<b>Abbreviations</b>	<b>viii</b>
<b>1 Introduction</b>	<b>1</b>
1.1 Motivational Background . . . . .	1
1.2 Objectives of the Thesis . . . . .	2
1.3 Thesis Structure . . . . .	3
<b>2 OpenAir Interface Platform</b>	<b>5</b>
2.1 Introduction to OpenAir Interface . . . . .	5
2.2 LTE Implementation in OpenAir Interface Architecture . . . . .	6
2.2.1 Control Plane Protocols . . . . .	7
2.2.2 User Plane Protocols . . . . .	8
2.3 Physical Layer Procedures . . . . .	10
2.3.1 Transmission Resource Structure . . . . .	10
2.3.2 Downlink Physical Layer . . . . .	12
2.3.3 Uplink Physical Layer . . . . .	19
2.4 Summary . . . . .	22
<b>3 Relaying and Cooperative Schemes</b>	<b>23</b>
3.1 Relaying in Cellular Networks . . . . .	23
3.2 Multiple Antenna Techniques . . . . .	25
3.3 Cooperative Schemes . . . . .	27
3.3.1 Delay Diversity Scheme . . . . .	28
3.3.2 Distributed Alamouti Scheme . . . . .	30
3.4 Channel Estimation for Cooperative Relays . . . . .	32

3.4.1	Requirement for Separate Channel Estimates . . . . .	33
3.4.2	Extraction of Separate Channel Estimates . . . . .	34
3.5	Summary . . . . .	37
<b>4</b>	<b>Hybrid-ARQ for Cooperative Schemes</b>	<b>38</b>
4.1	Bases for HARQ Scheme in Cooperative Communication . . . . .	38
4.2	Smart HARQ Schemes (SHARQ) . . . . .	40
4.2.1	SHARQ Scheme I . . . . .	40
4.2.2	SHARQ Scheme II . . . . .	40
<b>5</b>	<b>Simulator Description and Performance Analysis</b>	<b>42</b>
5.1	Simulator Overview . . . . .	43
5.2	Channel Modeling . . . . .	44
5.3	Simulation Parameters . . . . .	46
5.4	Results and Analysis of Relaying Scenarios without HARQ . . . . .	47
5.4.1	Downlink SNR vs Probability of Forwarding/Cooperation . . . . .	47
5.4.2	Uplink SNR vs Uplink BLER (phase 2) . . . . .	47
5.4.3	End-to-end BLER Performance of the System . . . . .	49
5.5	BLER Comparison of SHARQ schemes with no HARQ Scenario . . . . .	51
5.5.1	BLER Performance Comparison for Single Relay Case . . . . .	51
5.5.2	BLER Performance Comparison for Delay Diversity . . . . .	51
5.5.3	BLER Performance Comparison for Distributed Alamouti . . . . .	52
5.5.4	BLER Performance Comparison for All Scenarios . . . . .	53
5.6	Throughput Comparison of SHARQ schemes with no HARQ Scenario . . . . .	54
5.6.1	Throughput Performance Comparison for Single Relay Case . . . . .	55
5.6.2	Throughput Performance Comparison for Delay Diversity . . . . .	56
5.6.3	Throughput Performance Comparison for Distributed Alamouti . . . . .	57
5.6.4	Throughput Performance Comparison for All Scenarios . . . . .	57
<b>6</b>	<b>Conclusions and Future Work</b>	<b>60</b>
<b>A</b>	<b>Graphical Representation of Extracting Channel Estimates</b>	<b>62</b>
	<b>Bibliography</b>	<b>67</b>

# List of Figures

2.1	Radio Protocol Architecture . . . . .	9
2.2	Resource Blocks . . . . .	11
2.3	Resource Block Structure . . . . .	12
2.4	Frequency-Time Domain View of Radio Frame . . . . .	13
2.5	Transmission Chain . . . . .	14
2.6	Downlink Resource Element Mapping in LTE . . . . .	14
2.7	OpenAir Interface's Downlink Resource Element Mapping . . . . .	15
2.8	Channel Coding . . . . .	19
2.9	Resource Block Mapping for Uplink . . . . .	21
3.1	Basic Relaying System . . . . .	24
3.2	Frequency-Time-Space Domain View of Resource Block . . . . .	25
3.3	Cooperative Communication via Relays . . . . .	27
3.4	Delay Diversity Scheme Scenario 1: No ISI . . . . .	29
3.5	Delay Diversity Scheme Scenario 2: ISI Exists . . . . .	30
3.6	Combined Channel Estimate in the time-domain . . . . .	36
3.7	Channel Estimate in the Time-domain for Relay 0 . . . . .	36
3.8	Channel Estimate in the Time-domain for Relay 1 . . . . .	37
5.1	Distributed System Representation . . . . .	44
5.2	Downlink SNR vs Probability of Forwarding/Cooperation . . . . .	48
5.3	Uplink SNR vs Uplink BLER at 8dB Constant Downlink SNR . . . . .	49
5.4	Uplink SNR vs end-to-end BLER at 2dB Constant Downlink SNR . . . . .	50
5.5	Uplink SNR vs End-to-end BLER for Single Relay Case . . . . .	52
5.6	Uplink SNR vs End-to-end BLER for Delay Diversity . . . . .	53
5.7	Uplink SNR vs End-to-end BLER for Distributed Alamouti . . . . .	54
5.8	Uplink SNR vs End-to-end BLER for all Scenarios . . . . .	55
5.9	Uplink SNR vs End-to-end Throughput for Single Relay Case . . . . .	56
5.10	Uplink SNR vs End-to-end Throughput for Delay Diversity . . . . .	57
5.11	Uplink SNR vs End-to-end Throughput for Distributed Alamouti . . . . .	58
5.12	Uplink SNR vs End-to-end Throughput for all Scenarios . . . . .	59
A.1	Combined Channel Estimates in the Frequency-domain . . . . .	62
A.2	Combined Channel Estimates in the Time-domain . . . . .	63
A.3	Channel Estimates for Relay 0 in the Time-domain . . . . .	63
A.4	Channel Estimates for Relay 1 in the Time-domain . . . . .	64

---

A.5	Channel Estimates for Relay 0 in the Frequency-domain . . . . .	64
A.6	Channel Estimates for Relay 1 in the Frequency-domain . . . . .	65
A.7	Channel Estimates for Relay 0 in the Frequency-domain for One Subframe . . . . .	65
A.8	Channel Estimates for Relay 1 in the Frequency-domain for One Subframe . . . . .	66

# List of Tables

5.1 Simulation Parameters . . . . .	46
-------------------------------------	----



# Abbreviations

<b>3GPP</b>	Third Generation Partnership Project
<b>ACK</b>	ACKnowledgement
<b>AM</b>	Acknowledged Mode
<b>AS</b>	Access Stratum
<b>AWGN</b>	Additive White Gaussian Noise
<b>BCCH</b>	Broadcast Control CHannel
<b>BLER</b>	BLOCK Error Rate
<b>CCCH</b>	Common Control CHannel
<b>CDMA</b>	Code Division Multiple Access
<b>CIR</b>	Channel Impulse Response
<b>CQI</b>	Channel Quality Indicator
<b>CRC</b>	Cyclic Redundancy Code
<b>CTF</b>	Channel Transfer Function
<b>dB</b>	decibel
<b>DC</b>	Direct Current
<b>DCI</b>	Downlink Control Information
<b>DRB</b>	Data Radio Bearers
<b>DRS</b>	Demodulation Reference Signal
<b>FDM</b>	Frequency Division Multiplexing
<b>HARQ</b>	Hybrid Automatic Repeat Request
<b>HW</b>	Hardware
<b>HSPA</b>	High Speed Packet Access
<b>IDFT</b>	Inverse Discrete Fourier Transform
<b>IMT-A</b>	International Mobile Telecommunication - Advanced

---

<b>IP</b>	Internet Protocol
<b>ISI</b>	Inter - Symbol - Interference
<b>ITU-R</b>	International Telecommunication Union - Radio
<b>KHz</b>	KiloHertz
<b>LoS</b>	Line of Sight
<b>LTE</b>	Long Term Evolution
<b>MAC</b>	Medium Access Control
<b>MBSFN</b>	Multimedia Broadcast Single Frequency Network
<b>MCS</b>	Modulation Coding Scheme
<b>MHz</b>	MegaHertz
<b>MIMO</b>	Multiple Input Multiple Output
<b>NACK</b>	Non ACKnowledgment
<b>NAS</b>	Non Access Stratum
<b>OFDMA</b>	Orthogonal Frequency Division Multiple Access
<b>PAPR</b>	Peak-to-Average Power Ratio
<b>PCFICH</b>	Physical Control Format Indicator CHannel
<b>PDCCH</b>	Physical Downlink Control CHannel
<b>PDCCP</b>	Packet Data Convergence Protocol
<b>PDU</b>	Protocol Data Unit
<b>PHICH</b>	Physical HARQ Indicator CHannel
<b>PHY</b>	PHYsical
<b>PRB</b>	Physical Resource Block
<b>PUCCH</b>	Physical Uplink Control CHannel
<b>PUSCH</b>	Physical Uplink Shared CHannel
<b>QAM</b>	Quadrature Amplitude Modulation
<b>QoS</b>	Quality of Service
<b>QPSK</b>	Quadrature Phase Shift Keying
<b>RAT</b>	Radio Access Technology
<b>RB</b>	Resource Block
<b>RE</b>	Resource Element
<b>RF</b>	Radio Frequency

---

<b>RLC</b>	Radio Link Control
<b>RRC</b>	Radio Resource Control
<b>RS</b>	Reference Signal
<b>SAE</b>	System Architecture Evolution
<b>SAP</b>	Service Access Point
<b>SCFDMA</b>	Single Carrier Frequency Division Multiple Access
<b>SDU</b>	Service Data Unit
<b>SHARQ</b>	Smart Hybrid Automatic Repeat ReQuest
<b>SINR</b>	Signal to Interference Noise Ratio
<b>SNR</b>	Signal to Noise Ratio
<b>SRB</b>	Signaling Radio Bearers
<b>SRS</b>	Sounding Reference Signal
<b>SW</b>	SoftWare
<b>TA</b>	Timing Advance
<b>TBS</b>	Transport Block Size
<b>TDL</b>	Tapped Delay Line
<b>TM</b>	Transport Mode
<b>UE</b>	User Equipment
<b>UM</b>	Unacknowledged Mode
<b>UMTS</b>	Universal Mobile Telecommunication System
<b>WCDMA</b>	Wideband Code Division Multiple Access
<b>ZC</b>	Zadoff-Chu

*Dedicated*  
*to*  
*My Family, Friends & Dearest Zhenya*

# Chapter 1

## Introduction

This chapter provides the motivation and the background for the research work conducted and subsequently outlines briefly the main objectives of the thesis. The entire structure of the thesis report is given in the concluding section of the chapter.

### 1.1 Motivational Background

Wireless Communication Systems have witnessed continuous advancements in technology since their inception. With the transition over several generations, the third generation of mobile standards has been successfully deployed and accepted globally in the recent past. The perpetual transition has paved the way for the International Mobile Telecommunication Advanced (IMT-A) System, which is arguably called the 4<sup>th</sup> generation of mobile standards. However, “What has been the primary driving force for the evolution in wireless mobile communications?” The answer is:

*“To always improve what has already been achieved in terms of coverage, capacity and reliability for providing high quality mobile wireless services along with reduced costs [1].”*

With the contemporary cellular networks, there is a need to increase the density of base stations for meeting the requirements of increased coverage and capacity in order to provide high quality mobile services. But, the economic constraints as well as the infrastructural limitations make a network operator reluctant to readily deploy outdoor base stations in large numbers. So, a trade-off is reached between

the quality of service (QoS) provided to the users and the costs of deployment. Apparently, exploiting relay technology and/or deployment of femto-cells (home base stations) are envisioned as prominent solutions to the problem of weak radio links between distant nodes. The home base station promises to provide better indoor coverage, but the deployment of a base station in every home might not be feasible and globally acceptable. A more elegant solution therefore seems to be the introduction of relay technology in the future cellular networks.

As it is known, relayed communication as an individual technology has been studied for decades [2], but more recently, it has become one of the hot research topics in the field of mobile communications. Moreover, the concept of Multiple Input Multiple Output (MIMO) communications in cellular networks has given a new dimension to the concept of relaying technology which is described as a *Distributed Communication System via Relays* or *Cooperative Communications*. In a distributed system, different relays are considered as antennas of a single user, for which, then the multiple antenna techniques can be implemented. This concept gives a new terminology to the distributed system of cooperative relays which is described as Virtual-MIMO system. The key motivation for developing this system is to exploit the macro-diversity gain, obtained as a result of the uncorrelated fading along independent channel paths from relays to destination. Using the past studies in the area of distributed systems and their encouraging results [3], the key objectives of the thesis work are defined in the next section.

## 1.2 Objectives of the Thesis

The principal objective of the thesis work is to develop a system level simulator which implements cooperative schemes in a distributed system of relays on an OpenAir Interface Platform (to be addressed in *Chapter 2*). However, in order to attain this final implementation goal, a number of research objectives/challenges constituting the overall system need to be defined:

1. The first and the foremost requirement is to establish radio links between the source node and two relay stations and from the relay stations to the destination node, which is compliant with the standard defined for the platform.

2. How to extend the idea of diversity schemes (Space-Time Codes) from the scenario of multiple antennas in a single user to the scenario of distributed system of relays which cooperate as the virtual antennas of a single user?
3. What kind of channel estimation technique needs to be developed for facilitating transmission on the same set of resource blocks (RBs) for multiple relays?
4. Finally, one of the most challenging questions from the research perspective is how to develop a Hybrid-ARQ (HARQ) protocol for a distributed wireless system based on the cooperation of relays?

The next section outlines the structure of the thesis that distinctly provides solution to the above mentioned challenges.

### 1.3 Thesis Structure

The thesis is structured in a way such that each chapter provides a background for understanding every next topic, and by the concluding chapter of the report, the entire work becomes prominently clear in the reader's mind.

**Chapter 2** initially provides a background of the *OpenAir Interface Platform* and then describes the physical layer procedures associated with it, which are basically compliant with 3<sup>rd</sup> Generation Partnership Project - Long Term Evolution (3GPP LTE). Knowledge of the physical layer procedures assists in understanding the techniques developed during the thesis work.

**Chapter 3** briefly describes the relaying technology and MIMO techniques in general, which are further required for understanding the concept of cooperative communication via relays in the later sections. This chapter also deals with the challenge pertaining to channel estimation for multiple relays.

**Chapter 4** describes the HARQ schemes for the cooperative system of distributed relays, which would be expected to perform efficiently for such systems and significantly improve the end-to-end performance.

**Chapter 5** discusses the system level simulator developed during the thesis work which is based on the literature mentioned in previous chapters, then it illustrates the results obtained by extensive system level simulations and finally provides conceptual analysis of the results and the system.

**Chapter 6** at the end provides some concluding remarks about the work conducted during the thesis and the scope for future work/research in this area.



# Chapter 2

## OpenAir Interface Platform

This chapter introduces the OpenAir Interface Platform, which is further developed during the thesis work to implement the desired simulator. From the architecture point of view, the protocol stack is also briefly described in the chapter. However the main focus of the chapter is to ascertain the physical layer design and the procedures involved in the downlink and the uplink phase, which is required for understanding the advanced topics introduced and discussed in *Chapter 3* and *Chapter 4*.

### 2.1 Introduction to OpenAir Interface

The *OpenAir Interface* was created by the *Mobile Communications Department at Eurecom* to provide open-source (hardware and software) wireless technology platforms. The main idea behind its development is to boost innovation in air-interface technologies through experimentation. It is an integrated RF/HW/SW wireless radio platform for experimentations in medium-scale deployment and has two modes of operation: Hard Real-time Mode and Soft Real-time Mode. The hard real-time mode of operation is run on Linux under the control of a real-time application interface which provides low latency two-way communication. The soft real-time mode of operations runs in Linux user-space while maintaining the frame timing on average. OpenAir Interface's principal areas of research are:

1. *Real-time Radio Signal Processing*: This deals with the development of hardware/software architectures for supporting real-time signal processing. It provides

physical layer support for cellular and mesh network topologies including algorithmic optimizations.

2. *All-IP Wireless Networking*: This area provides layer 2 protocols (MAC scheduling, Radio Resource Control, Radio Link Control) for cellular and mesh network topologies.

3. *Agile RF system Design*: This includes wideband radio design with linear wide-dynamic range receivers.

4. *Design and Simulation Methodologies*: It serves efficient simulation methods for performance, functional and behavioral analysis and also provides RF emulation architectures for distributed real-time simulation of wireless networks.

5. *Propagation and System Measurements and their Analysis*: This facilitates wideband channel characterization and modeling along with real-time measurements collection for performing offline empirical analysis.

6. *Cognitive Radio*: It deals with the development of innovative techniques based on sensor networks that can support the co-existence of licensed and unlicensed wireless users. This branch basically handles design, dimensioning and inter-networking of cognitive networks.

The OpenAir Interface aims to make significant advances in terms of spectral, algorithmic and protocol efficiency, even ahead of industrial air interface standards such as 3GPP LTE, 802.16m, etc.

## **2.2 LTE Implementation in OpenAir Interface Architecture**

The Long Term Evolution of UMTS has been one of the most significant accomplishments in the series of mobile telecommunication systems. From the radio aspects, the 3GPP has evolved over three multiple access technologies: Time and Frequency-Division Multiple Access (Second Generation), Code Division Multiple Access which later on developed as Wideband CDMA (owing to 5 MHz carrier bandwidth) and finally it adopted Orthogonal Frequency-Division Multiplexing which is now widely accepted in other mobile standards. Furthermore, it has

evolved also from the non-radio aspects, i.e. described as *System Architecture Evolution* (SAE) [4]. LTE along with SAE comprises of the Evolved Packet System where both the core network and the radio access are fully packet-switched. The latest generation of 3GPP LTE is defined as LTE-Advanced which has been developed keeping in mind the requirements laid down by ITU-R for IMT-Advanced systems. The requirements for 3GPP have been evolving over time to satisfy the user's expectations as well as the operator-driven requirements. The OpenAir Interface has principally been derived from the 3GPP LTE standard, in order to evolve in parallel with this globally accepted mobile standard. The idea has been to develop an open-source implementation of a subset of LTE Release-8 on top of its software architecture and hardware demonstrators. The main motivation behind this derivation is to have a full compliance with the LTE Radio Interface. With this conformity to the LTE standard, it would be possible to make new advancements in air-interface technologies which will also be justifiable to LTE-Advanced systems and the future generations of 3GPP LTE.

Being compliant with the 3GPP LTE standard, the protocol architecture of the OpenAir Interface is similar to that of LTE and therefore the procedures related to every layer of the stack are mostly similar.

The protocol architecture is designed as a layered structure with the *Access Stratum (AS)* comprising of Layer1 and Layer 2. The AS further interacts with the *Non-Access Stratum (NAS)* which is also referred to as the upper layer. *Figure 2.1* illustrates the radio architecture of the OpenAir Interface platform which has an LTE-like protocol stack. At the bottom of the stack, is the Physical layer (also referred as Layer 1), which is responsible for (de)coding, (de)modulation, multiple antenna techniques and other related procedures. The physical layer exchanges data with higher layers through the transport channels between them. The procedures and channels associated with the PHY layer are discussed in detail in *Section 2.3*. Layer 2 on the other hand, has multiple protocol entities which are categorised as control plane protocols and user plane protocols.

### 2.2.1 Control Plane Protocols

The control plane of the AS handles the radio specific functionality. The applicable AS related control procedures mainly depend on the Radio Resource Control (RRC) protocol.

**Radio Resource Control:** The RRC protocol is the main controlling function in the AS which is being responsible for establishing radio bearers and configuring lower layers using RRC signaling between eNodeB and the User Equipment (UE). Unlike WCDMA/HSPA, UE here has two states: RRC\_CONNECTED and RRC\_IDLE, depending on whether the RRC connection is established or not. The following are the main functional areas associated with the RRC protocol:

1. *System Information:* This area deals with broadcasting the system information that includes NAS common information, of which some system information is applicable for the UE in RRC\_CONNECTED while some other is applicable in RRC\_IDLE.
2. *RRC Connection Control:* It includes all the procedures related to the establishment, modification and release of an RRC connection. It also covers establishment of Signaling Radio Bearers (SRBs) and of radio bearers carrying user data (Data Radio Bearers, DRBs) and configuration of lower protocol layers.
3. *Measurement Configuration and Reporting:* It includes configuration and activation of measuring gaps. It measures configuration and reporting for intra-frequency, inter-frequency and inter-RAT mobility.
4. *Network Controlled inter-RAT Mobility:* This deals with the security activation and transfer of the UE RRC context information.

## 2.2.2 User Plane Protocols

The user plane protocol stack for Layer 2 comprises of 3 sub-layers:

**1. Medium Access Control (MAC) Layer:** The MAC layer is the lowest sub-layer in the stack which communicates with the physical layer below it through transport channels and through logical channels with the higher layers. Therefore it basically performs multiplexing and demultiplexing between logical and the transport channels. It does multiplexing of the MAC SDUs from logical channels onto transport channels delivered to the physical layer on transport blocks and then demultiplexing from transport blocks received from transport channels. The main functions of MAC layer involves the reporting of scheduling information for priority handling between UEs, transport format selection and error control through Hybrid-ARQ (HARQ).

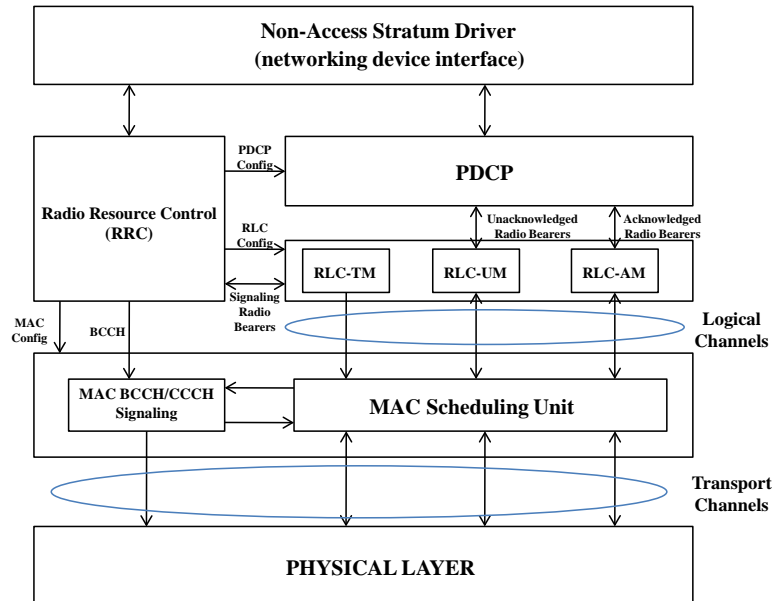

FIGURE 2.1: Radio Protocol Architecture

2. **Radio Link Control (RLC) Layer:** The RLC layer is located between the MAC layer from the bottom and the PDCP layer from the top. It uses the Service Access Point (SAP) to communicate with the higher layer i.e. PDCP and logical channels to communicate with the MAC layer. The RLC layer exists in three modes: *Transport Mode*, *Unacknowledged Mode* and *Acknowledged Mode*. The TM RLC entity has very restricted usage since only RRC messages, which do not require RLC configuration need it, such as padding messages. The main functions of UM RLC are segmentation and concatenation of RLC SDUs, reordering of RLC PDUs, duplicate detection of RLC PDUs and reassembly of RLC SDUs and the functions of AM RLC can be summarized as retransmission of RLC Data PDUs, re-segmentation of retransmitted RLC Data PDUs, polling, status reporting and status prohibiting.

3. **Packet Data Convergence Protocol (PDCP) Layer:** The PDCP is the uppermost layer in Layer 2. The major functions of this sub-layer are header compression and decompression for user plane data, security functions such as ciphering and deciphering for both plane and handover support functions. It also

involves integrity protection and verification, to ensure that control information is coming from correct source.

The Layer 2 protocol stack therefore acts as an interface between the radio access technology (RAT) and the lower PHY layer which enables its efficient utilization for packet data traffic.

## 2.3 Physical Layer Procedures

This section describes the procedures involved in the physical layer of the platform for both the downlink and the uplink. More importantly, it specifically points out the limitations/modifications that exist in the OpenAir Interface platform with respect to the 3GPP LTE standard.

### 2.3.1 Transmission Resource Structure

The OpenAir Interface platform has a transmission resource structure similar to that of LTE. In LTE, downlink/uplink transmissions possess time, frequency and space dimension. The space dimension is exploited by means of multiple antenna techniques which are described in *Chapter 3*.

In the frequency-domain, the notion of a Resource Block (RB) is defined which represents the minimum scheduling resource for both the downlink and the uplink as illustrated in *Figure 2.2*.

As LTE is specified for any bandwidth between 1.08MHz and 19.8MHz which is a multiple of 180KHz, so a Physical Resource Block (PRB) corresponds to a size of 180KHz of spectrum. Depending on the channel bandwidth, the number of PRBs is defined which in case of OpenAir Interface is 5MHz that corresponds to 25 PRBs. Furthermore, each PRB is chosen to be equivalent to 12 subcarriers with an individual spacing of 15KHz. The subcarrier is termed as a Resource Element (RE) which is the smallest unit of a transmission resource. These PRBs with REs are mapped onto the contiguous time-domain symbols for downlink/uplink transmission. In the time-domain, the largest unit of time is a radio frame which corresponds to a duration of 10ms. Each frame is then further subdivided into 10 subframes of 1ms, each of which is split into 2 slots of 0.5ms. Each slot comprises

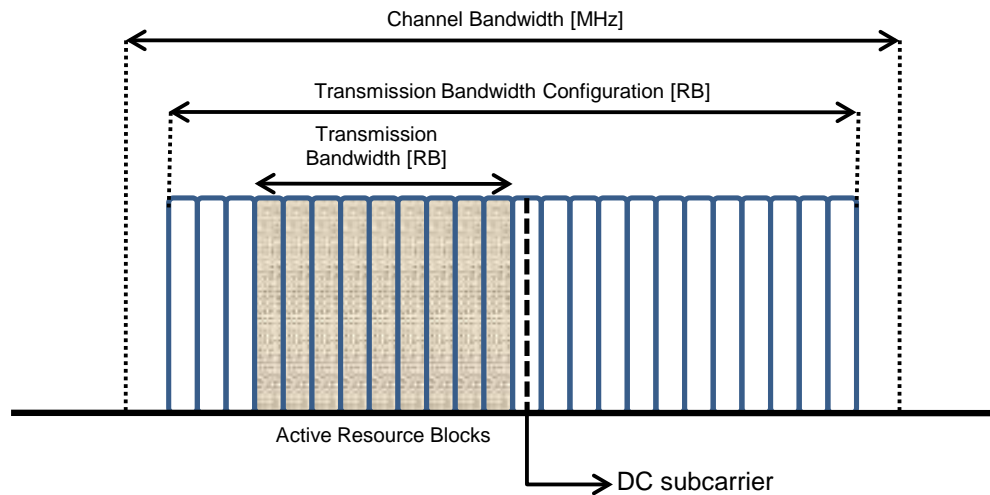

FIGURE 2.2: Resource Blocks

either 6 time-domain symbols in case of the extended cyclic prefix mode or 7 symbols for the normal cyclic prefix mode. Within the PRBs, certain REs are reserved for special purposes such as synchronization signals, reference signals and control signaling which are specific to the downlink and uplink transmission. The remaining REs are used for the useful data to be transmitted. The specific configurations will be studied in the subsequent sections of this chapter.

For a single time slot, the detailed resource block structure is shown in *Figure 2.3* with 5MHz channel bandwidth and normal cyclic prefix length. As mentioned earlier for 5MHz channel bandwidth, the number of PRBs is 25 corresponding to one time-domain symbol, with 300 REs. These are basically the non-zero subcarriers, with the total size being equal to the IDFT length which is 512 for the current configuration in the OpenAir Interface. Therefore every time-domain symbol corresponds to a total number of 512 subcarriers in the frequency-domain.

Now, *Figure 2.4* illustrates the frequency-time domain view of the complete radio frame of 10ms for both the cases of normal cyclic prefix length and extended cyclic prefix length. As can be seen in the figure, in the case of a normal cyclic prefix, the symbol 0 has a different cyclic prefix length when compared with other symbols. This is done in order to accommodate the integral number of symbols for normal cyclic prefix mode. For the extended cyclic prefix mode, all the symbols have equal cyclic prefix length.

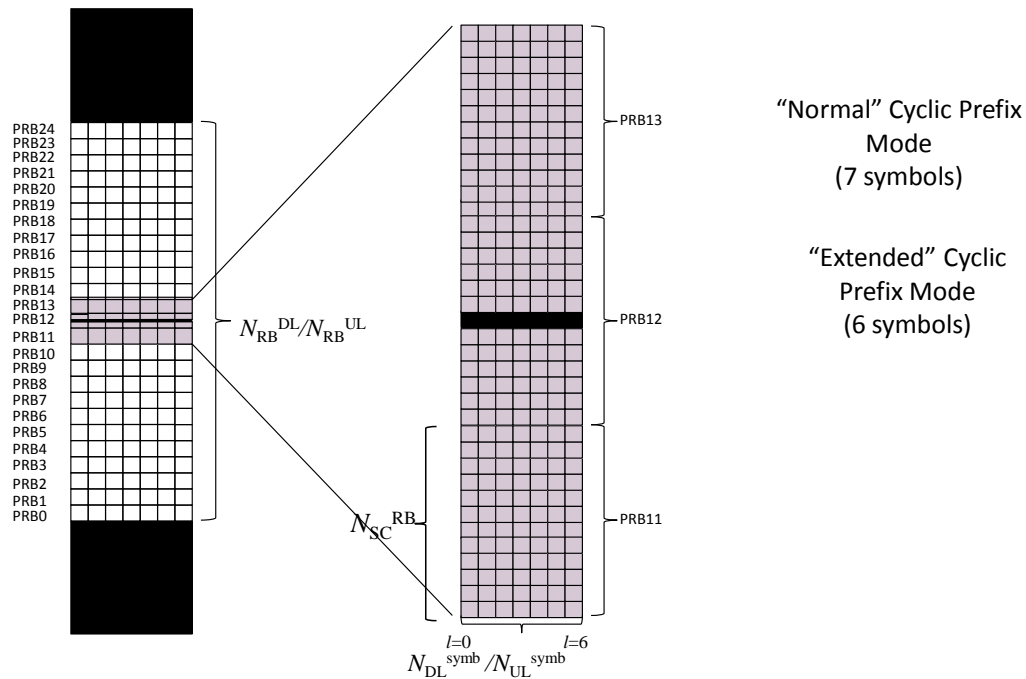

FIGURE 2.3: Resource Block Structure

The current hardware configuration of the OpenAir Interface is based on extended cyclic prefix length.

### 2.3.2 Downlink Physical Layer

In downlink transmissions, the transmit signal is comprised of user plane data and control plane data from higher protocol layers which are multiplexed with the physical layer signaling to enable the transmission from eNodeB to the UE. This is facilitated by Orthogonal Frequency Division Multiple Access (OFDMA), a special case of multicarrier transmission in which the adjacent subcarriers are orthogonal to each other. Due to the space constraint, the OFDMA technique is not described here, but the interested readers can refer to [5, 6].

#### Transmission Chain

The data generated from the source undergoes a number of procedures before being transmitted from eNodeB in downlink, since the data block needs to be made reliable and protected against transmissions and channel errors. Therefore the



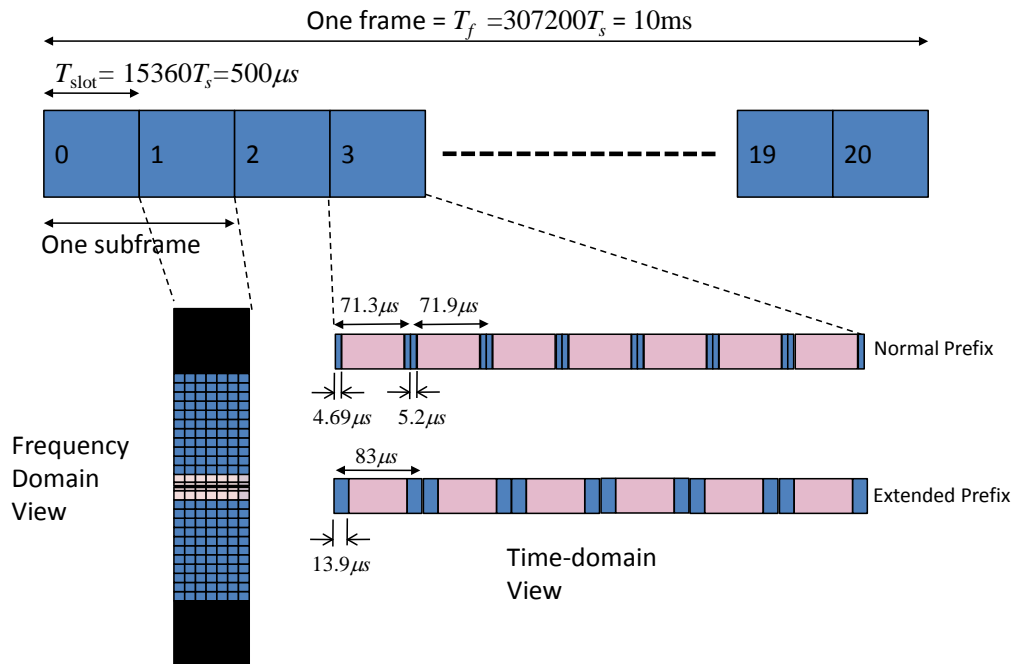

FIGURE 2.4: Frequency-Time Domain View of Radio Frame

primary role of the physical layer is to translate data into a reliable signal for transmission across the radio interface between eNodeB and the UE. The data block is first protected with a Cyclic Redundancy Check (CRC) and then with channel coding. As illustrated in *Figure 2.5*, after the codeword is generated, a scrambling sequence is applied which serves the purpose of interference rejection. Following the scrambling stage, data bits are mapped onto modulation symbols depending on the modulation scheme. In LTE QPSK, 16QAM and 64QAM modulation schemes are used. Later, the advanced procedures relevant to multiple antenna transmission are applied along with OFDM signal generation at the end.

### Signal Structure

The data symbols to be transmitted are multiplexed along with the synchronization, control and reference signals for a robust and reliable transfer of information, which are mapped to the resource blocks according to a defined format as per the specifications. In LTE, a possible downlink REs mapping for a 2 transmit antennas scenario is illustrated in *Figure 2.6*.

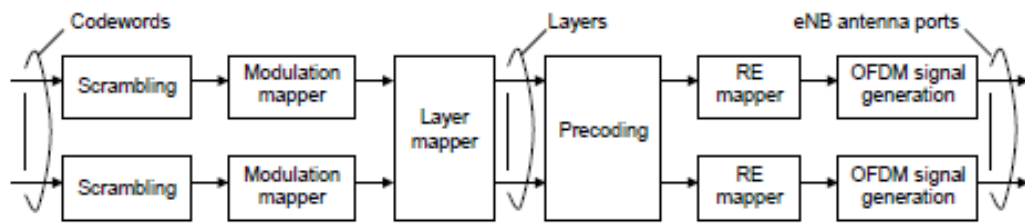

FIGURE 2.5: Transmission Chain

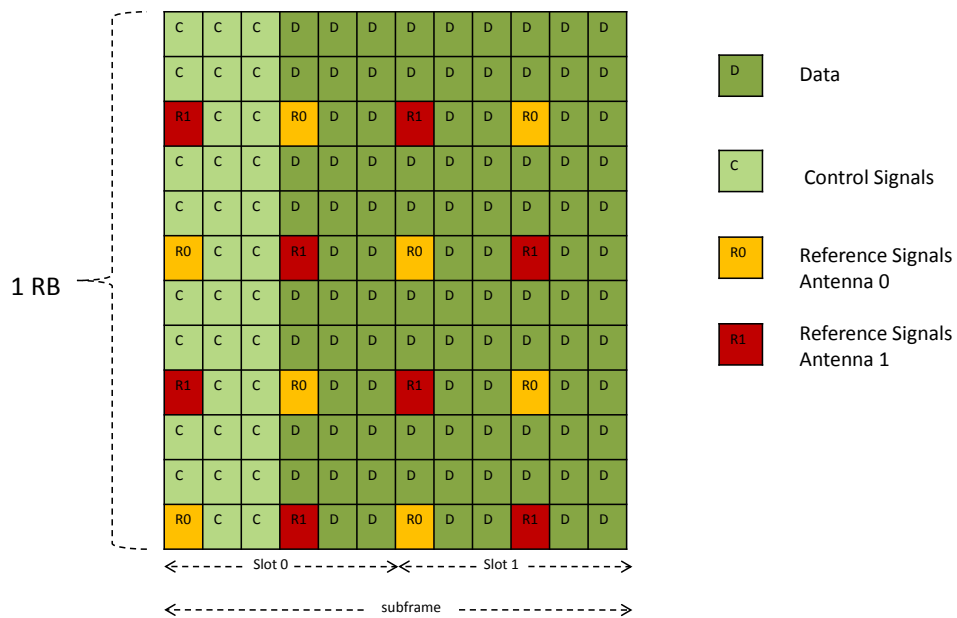

FIGURE 2.6: Downlink Resource Element Mapping in LTE

The mapping in the figure above is indicated for the case when the entire resources are used for downlink transmission which is applicable to the system developed in the thesis work. The transmission time interval used is one subframe, comprising 2 time slots which are further composed of 6 symbols each. The symbols are spread over an entire bandwidth of 5 MHz equivalent to 25 resource blocks.

However the OpenAir Interface implements a slightly modified version of signal mapping to the resource elements which is indicated in *Figure 2.7*. As can be seen

in the figure, the REs carrying the reference signals are not utilized for data transmission which results in a transport block size equal to  $3/4$  of the transport block size in LTE. The motivation behind using such mapping is to avoid interference to the reference signals from the adjacent eNodeB symbols in the case of multiple eNodeBs.

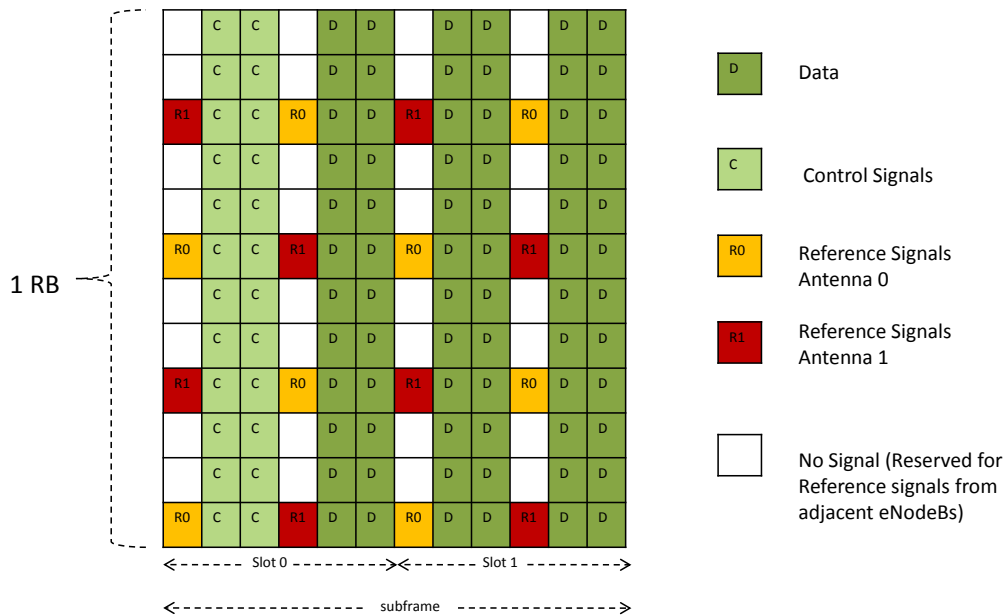

FIGURE 2.7: OpenAir Interface's Downlink Resource Element Mapping

The synchronization signals indicated in the figure enable the UEs to synchronize with the network and perform cell search procedures. The UE determines the time and frequency parameters from the synchronization signal that are necessary to demodulate the downlink and transmit the uplink signals. The details of the synchronization signals are not discussed here due to space constraints, however specific functions associated with the control signals and reference signals are discussed here due to their relevant impact on the simulator developed during the thesis.

**Control Signals** The control signals illustrated in the figure provide support to the data transmission from eNodeB to UE by indicating the REs in the block

structure that consist of the user and type of format used for supporting transmission. Control-Signaling channels are used for carrying the controlling overhead which are basically distinguished as Data Associated Control Signals and Data non-Associated Control Signals. Data non-Associated control signals are carried by channels such as Physical Control Format Indicator Channel (PCFICH) and Physical Hybrid-ARQ Indicator Channel (PHICH). PCFICH is used to indicate the format used by the control signals themselves and PHICH constitutes the HARQ related information.

Data Associated control signals are carried by the Physical Downlink Control Channel (PDCCH). They carry a specific message known as the Downlink Control Information (DCI). After the synchronization is established, the most important step is to correctly decode the DCI since its this message which contains all the necessary information associated with the data transmission and which is required for further processing of the signal. A number of DCI formats are defined in the specification, one of which is used depending upon the system configuration. An advantage of using a pre-defined DCI format is to get rid of long overhead information. This message carries various pieces of information depending upon the system. Resource block assignment, spatial layers information, precoding scheme, modulation and coding scheme, power control command, etc are all indicated by the DCI. Therefore if the DCI is not decoded correctly, further processing is not possible and it results in block error. For a detailed information of all the formats available, readers can refer to version 8.6 on [7].

**Reference Signals** The reference signals enable accurate channel estimation for coherent detection at the receiver. In LTE, there are three types of reference signals specified: Cell Specific reference signals, User specific reference signals and Multimedia Broadcast Single Frequency Network (MBSFN) specific reference signals. However in the platform, only cell-specific reference signals are utilized.

Cell-specific RSs are common to all the UEs in a single cell. As indicated in the downlink resource block structure, the reference signals are evenly spaced in the frequency and time-domain. The time spacing of the reference signals is obtained by considering the maximum doppler spread to be supported. Therefore based on the specifications, two reference signals per slot are placed for correct channel estimation. The frequency-domain spacing of RSs is obtained from the expected coherence bandwidth of the channel which is related to the channel delay spread. In LTE, cell specific RSs for 4 antenna ports can be utilized by eNodeB which

facilitates four separate channel estimates. *Figure 2.7* illustrates the reference signals for a 2 transmit antennas case. A detailed RS-aided channel estimation procedure is explained in the next section.

### RS-aided Channel Estimation

In LTE downlink, the channel estimation can be carried out either in the frequency-domain or in time-domain depending on the specific requirements of the system. The OpenAir Interface platform implements frequency-domain channel estimation which relies on the reference signals spread over one symbol along different sub-carriers. With the evenly spaced RSs, the Channel Transfer Function (CTF) is estimated in the frequency-domain at the REs containing the RSs by de-correlating with the constant modulus RS. The received symbol at the REs containing RSs is given by:

$$Y_k^n = H_k^n S_k^n + Z_k^n \quad (2.1)$$

where  $n$  denotes the symbol index,  $k$  denotes the RE index,  $Y$  is the received signal,  $X$  is the transmitted signal,  $H$  is the CTF and  $Z$  is the noise.

The CTF is then estimated for the REs containing the reference signals by de-correlating with the constant modulus RS.

$$\hat{H}_k^n = Y_k^n S_k^{n*} \quad (2.2)$$

$$\text{Estimate} \rightarrow \hat{H}_k^n = H_k^n + \tilde{H}_k^n \leftarrow \text{EstimationError} \quad (2.3)$$

The CTF for all the REs containing the RSs across every symbol is estimated using the above mentioned procedure. The channel estimates for the remaining REs containing data and other signals can then be calculated using different types of interpolator. The Linear Interpolation Estimator [8] has been used for frequency and time-domain interpolation in the OpenAir Interface platform. The following set of equations indicates the linear interpolation and also extrapolation that is required for the REs at the edge of the bandwidth.

Interpolation in the frequency-domain:

$$\hat{H}_1^0 = 5/6 * \hat{H}_0^0 + 1/6 * \hat{H}_6^0 \quad (2.4)$$

Extrapolation in the frequency-domain:

$$\hat{H}_{10}^0 = 7/6 * \hat{H}_9^0 - 1/6 * \hat{H}_3^0 \quad (2.5)$$

Interpolation in the time-domain:

$$\hat{H}_1^0 = 2/3 * \hat{H}_0^0 + 1/3 * \hat{H}_3^0 \quad (2.6)$$

Thus using the above linear interpolation estimator [8], the channel estimates corresponding to every RE is obtained correctly.

### **Adaptive Modulation and Coding**

In a cellular mobile system, the signal received by the UE is dependent on the channel quality, interference level and the noise level. In order to optimally utilize the resources, the transmitter should be able to adapt dynamically with the changing channel conditions. This process is basically referred to as link adaptation which is based on Adaptive Modulation and Coding. It is facilitated by an input at the transmitter which is called Channel Quality Indicator (CQI) feedback. The UE send this feedback on the uplink indicating the data rate that can be supported by the channel. Due to its adaptive nature, LTE offers a link adaptation feature in combination with HARQ. They work on the principle of incremental redundancy where the coding rate is reduced with every repeat request which provides more robustness to the channel fading. The coding rate is progressively reduced by additional parity information with each retransmission. For poor channel conditions, a lower code rate is used whereas a higher code rate in the case of a high Signal to Interference plus Noise Ratio (SINR). HARQ with incremental redundancy is further discussed in *Chapter 4*, where efficient retransmission schemes for cooperative system of distributed relays are researched for implementation.

The OpenAir Interface platform is compliant with 3GPP LTE with respect to downlink shared channel in terms of transport block CRC, channel coding, rate matching and code block concatenation. This guarantees the representability of

results for user plane data. The downlink shared channel implementation supports up to 8 HARQ processes. *Figure 2.8* illustrates the coding chain applied in the platform. A Sub-block interleaver is applied which further enhances the performance of the channel coding procedure. Rate matching is performed using circular buffer rate matching that has been selected for LTE as it generates puncturing patterns for any arbitrary code rate with excellent performance. After rate matching, the codeword is then processed along the transmission chain as described earlier.

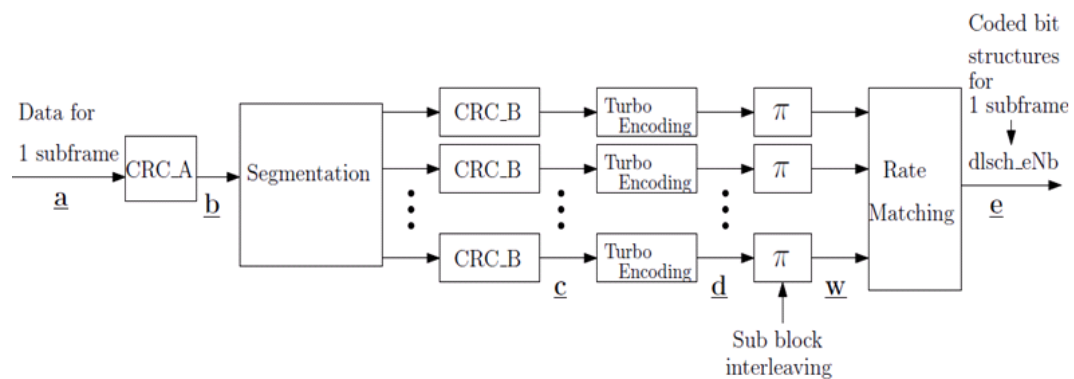

FIGURE 2.8: Channel Coding

Link Adaptation feature in the platform also facilitates adapting the modulation scheme used with varying channel conditions. As mentioned earlier, 3GPP LTE supports QPSK, 16QAM and 64QAM which are used as available modulation schemes.

### 2.3.3 Uplink Physical Layer

In a cellular network, the motivation has always been to have a reduced complexity, to support multiple users in a cell and to have a low power consumption at the UE side. Therefore with this motivation in mind, LTE for obvious reasons has some variations in the uplink physical layer to address specific requirements in the uplink transmission. This section gives an overall view of the differences that exist in the uplink physical layer design with respect to downlink. The first and foremost requirement for the uplink is to have a low Peak-to-Average Power Ratio (PAPR) to avoid excessive size and power consumption at the UE. Other requirements such as to have orthogonal transmission for the users in a single cell could

have been addressed by OFDMA, however it has an inherent disadvantage of high PAPR. Therefore Single-Carrier Frequency Division Multiple Access (SC-FDMA) replaced OFDMA in the uplink phase in LTE which has a relatively low PAPR and satisfies other requirements also for uplink. Interested readers can refer to [9, 10] for detailed discussion on SC-FDMA. The OpenAir Interface, initially has used OFDMA for uplink for simplicity issues. Although very recently, the platform has shifted to SC-FDMA in the uplink, the system developed in this thesis work still however uses OFDMA for the uplink transmissions.

In the uplink, the RE mapping is also different when compared to that of downlink. *Figure 2.9* shows the RE mapping used for the system developed on the OpenAir Interface. This mapping is applicable to the case of a single user in a cell or when more than one user uses exactly the same set of REs for transmitting the reference signals which is valid for our system. However the requirement for the case above is to have orthogonal reference signals for obtaining separate channel estimates for all users (to be discussed in *Chapter 3*).

As can be seen in *Figure 2.9*, the control signals occupy the edge of the bandwidth in the RB structure and the remaining bandwidth is used for reference signals corresponding to specific time-domain symbols and the remaining symbols are used for data. In uplink, there exists a significant difference in the control signaling with respect to the downlink phase. Due to multiple users in the same cell, there is a requirement for centralized resource allocation in uplink which is provided by eNodeB. Therefore all the relevant information associated with the data is already known at eNodeB which eliminates the necessity of transmitting data associated control signals contrary to downlink which transmits DCI. Hence only data non-associated control signals similar to downlink exist in uplink which uses the Physical Uplink Control Channel (PUCCH). The PUCCH takes care of HARQ ACK/NACK, CQI and MIMO feedback.

Reference signals in uplink further consist of two types: the Demodulation Reference Signal (DRS) and the Sounding Reference Signal (SRS), each one of them being utilized for specific purposes. DRS are associated with the transmission of uplink data on the Physical Uplink Shared Channel (PUSCH) and control signaling on the PUCCH. The primary purpose of DRS is to estimate a channel for coherent demodulation at the receiver similar to that of downlink. However DRS uses a special type of sequences called as Zadoff-Chu (ZC) sequences. These sequences satisfy the desirable properties for uplink RSs to provide good autocorrelation



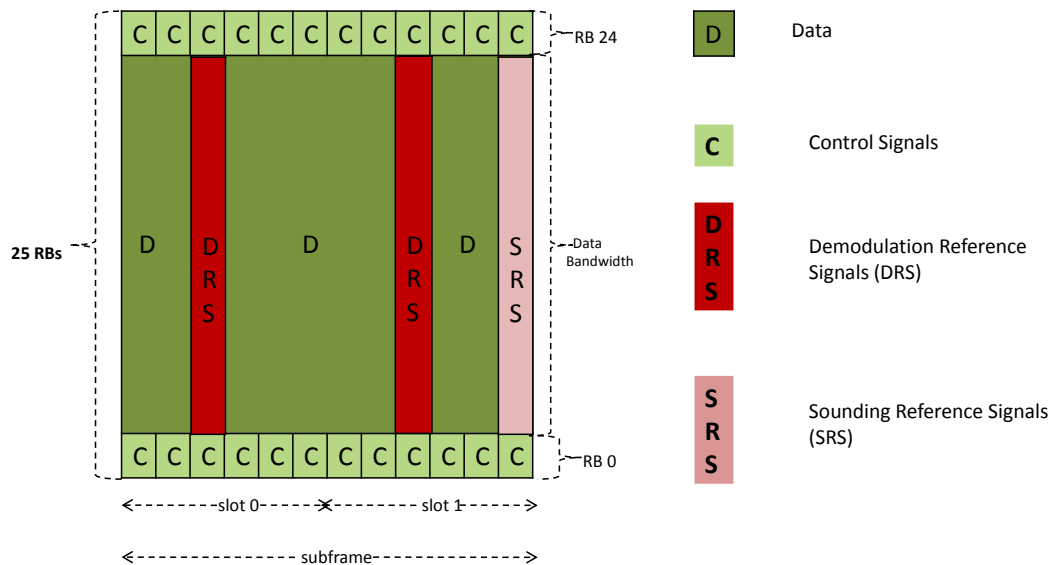

FIGURE 2.9: Resource Block Mapping for Uplink

properties for accurate channel estimation and also good cross-correlation properties between different RSs to cancel out interference from the RSs transmitted on the same resources. This inherent property of ZC sequences would be discussed in *Chapter 3*, where it is utilized for facilitating separate channel estimation for two users in the same cell using same RBs.

The SRS are primarily used for channel quality estimation to exploit frequency selective fading on the uplink. In the configuration used for the system developed in thesis, the SRS is transmitted on the last symbol of every subframe in order to provide channel quality after every subframe and to enable other functions such as MCS selection, power control, timing advance, etc.

Thus based on this signal structure and using procedures similar to that of downlink, the uplink physical layer is designed for the OpenAir Interface.

## 2.4 Summary

The physical layer procedures described in this chapter form the basis of the system developed during the thesis work on the OpenAir Interface platform. With the detailed description of the physical layer procedures for the downlink and the uplink in this chapter, now the reader is expected to have an adequate background to understand the implementation of channel estimation and HARQ processes for cooperative schemes in a distributed system of relays.

# Chapter 3

## Relaying and Cooperative Schemes

This chapter begins with a discussion on the relaying technology and the multiple antenna techniques in general and how they enhance the system performance in a cellular mobile network. Based on the aforementioned techniques, the chapter then describes the concept of cooperative schemes in a distributed system of two relays, whose implementation in the OpenAir Interface is the primary objective of this thesis work. Finally, the most challenging task of correct channel estimation for the cooperative scheme is provided with an effective solution which is implemented in the system.

### 3.1 Relaying in Cellular Networks

In a cellular network, one of the most prominent issues has been the lack of reliable coverage, improved capacity and throughput to the cell edge users. Deployment of an increased number of base stations is an obvious solution to the issue, however this is not a complete solution when economic and infrastructural constraints are taken into account.

Relaying networks have been looked upon as one of the few eminent solutions to this problem in the future generation of mobile communications, i.e. IMT-Advanced Systems [11]. A relay station is neither a source nor a destination but an intermediate station which receives the signal transmitted from the source, after

which it applies one of the forwarding schemes available and finally retransmits the signal to the destination. Consequently, the link between the source and the destination with a low signal strength splits into multiple links with a stronger signal. During the period of this thesis work, the notion of a relay station was still not standardized which means that either an eNodeB or an UE can be considered as a relay station. However with respect to the system developed in this thesis, a UE terminal is considered as a mobile relay station. The most basic 2-hop relay system is illustrated in *Figure 3.1*.

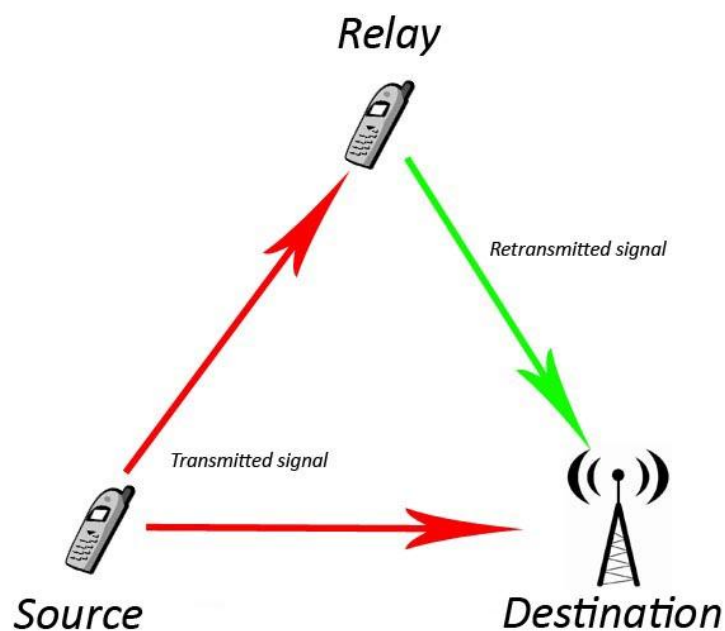

FIGURE 3.1: Basic Relaying System

In the configuration shown in the figure, the UE terminal and an eNodeB represent the source and the destination respectively. Perhaps a number of other configurations are possible depending on the representation of source and destination. The configuration specific to the system developed for the thesis is illustrated in *Chapter 5*. Introduction of a relay station to the system enables a better signal strength compared to that of a case without any relay station, with most significant advantage being the provision of better coverage without any extra infrastructural investments [12]. The principle goal of the thesis work, however, has not been to

demonstrate the benefits of relaying, but to exploit its merits in combination with MIMO technology, a relatively novice yet prominent advancement in the field of wireless communications. The next section describes the fundamentals of multiple antenna techniques in general and then *Section 3.3* extends the concept of MIMO schemes to a distributed system of relays and illustrates the resulting idea known as Cooperative Communication via Relays.

## 3.2 Multiple Antenna Techniques

The invention of MIMO systems in the mid 1990s was the first step in the direction of realizing multiple antenna techniques as a key component for advanced mobile cellular networks. Before the MIMO systems were introduced, wireless communications had exploited only time and frequency-domain processing of signals. But the addition of multiple antennas to a single user gave a new dimension of spatial processing to the signals in wireless communication. *Figure 3.2* shows a transmission RB structure in a 3-dimension, i.e. frequency-time-space.

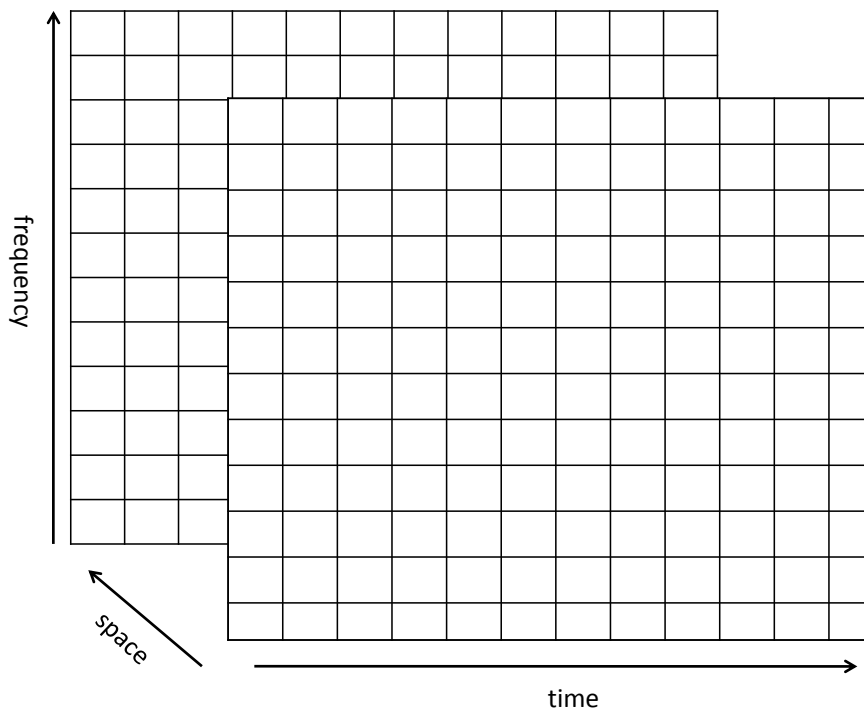

FIGURE 3.2: Frequency-Time-Space Domain View of Resource Block

Multiple antenna wireless communication systems significantly provide much better performance in terms of block error rate (BLER) and throughput than single antenna systems. With the deployment of multiple antennas at the transmitter and/or receiver, a MIMO communication system significantly improves the performance without additional bandwidth or transmission power. This is achieved by either transmitting independent data streams on all antennas or transmitting coded and correlated signals on its antennas [13]. Transmitting independent data streams results in spatial multiplexing gain and transmitting coded and correlated signals on its antennas result in diversity gain. The main advantage of spatial multiplexing is to enable high data rates by sending multiple streams depending on the number of transmitting and receiving antennas, without increasing the bandwidth. The streams are separated at the receiver by the spatial signature associated with them.

From the viewpoint of this thesis work, the motivation has been to exploit the diversity gain in a distributed system of relays. Before further discussing the cooperative schemes, it is appropriate to explain how the diversity gain is achieved in a MIMO system and the constraints associated with it. Diversity gain is a means to combat multipath channel fading by means of transmitting and/or receiving over different antennas at which fading is sufficiently de-correlated. The spacing between the individual antenna elements must be large enough so that uncorrelated spatial fading can be observed at different antennas. However, due to the limited size of the portable devices, there is a practical limitation on the number of antennas integrated on portable devices which limits the possible gains for existing MIMO systems.

Diversity gain is fundamentally related to the improvement of the statistics of the instantaneous Signal-to-Noise Ratio (SNR) in a fading channel. Perhaps, diversity gain can be achieved by using diversity schemes either at the transmitter or at the receiver. The transmit diversity schemes are preferred in scenarios with low SNR, low mobility or low delay tolerance. A number of transmit diversity schemes have been discussed for the LTE MIMO systems. In this thesis, two transmit diversity schemes are implemented for a distributed relay system which are discussed in detail in the next section. The encouraging gains and advantages associated with MIMO techniques and the relaying system, provide a strong motivation to combine the two technologies and meet the challenges involved in successful implementation of a system level simulator for these schemes.

### 3.3 Cooperative Schemes

Cooperative wireless communication in a distributed system of relays is described as *forwarding precoded signals from all the active relay stations, which are correlated in a pre-defined manner to exploit maximum possible spatial diversity gains, in order to provide better reliability, improved capacity & coverage and enhance the overall performance of the system in comparison to a single relay system* [14]. This idea of cooperative wireless communication via a distributed system of relays is also referred to as a virtual MIMO system due to its derived relation from a real MIMO system. *Figure 3.3* shows a distributed system of two relays which cooperate in order to exploit the spatial diversity gain.

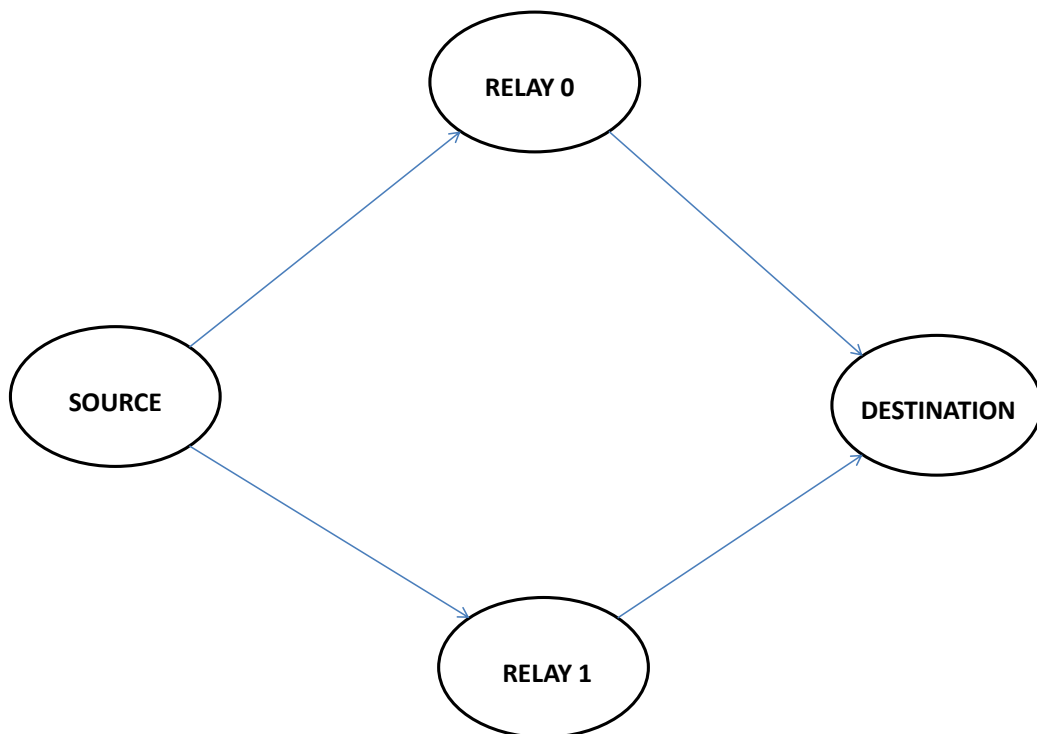

FIGURE 3.3: Cooperative Communication via Relays

In the past, studies related to the field of cooperative communication have provided considerable attention and motivation to implement the cooperative schemes on an LTE compliant platform [15]. During the thesis, the two cooperative schemes implemented for a relaying network are: the Delay Diversity Scheme and Distributed Alamouti Scheme which are basically derived from the transmit diversity schemes

described for MIMO systems in LTE (*Chapter 11* of [16]). From the implementation point of view in a system, the two schemes have a very contrasting nature and therefore it becomes interesting to examine both the schemes and to find out the one which has a better trade-off between the complexity and the diversity gains. *Section 3.3.1* and *Section 3.3.2* discuss the advantages of using these schemes, the related constraints and the challenging tasks for successful implementation.

### 3.3.1 Delay Diversity Scheme

Diversity can be achieved via any of the three dimension of the signal i.e. time-frequency-space at the transmitter and/or at the receiver. Delay diversity is attributed to either the introduction of an artificial relative delay between the two relays or utilizing the inherent relative delay caused due to the different channel paths from the relay stations to the destination. The macro-diversity is fundamentally achieved due to the two independent and uncorrelated channels and furthermore, the relative delay between the two links significantly enhance the system performance by introducing frequency selectivity in the overall channel of the radio link [17]. This type of delay diversity is basically referred to as Linear Delay Diversity.

**Merits of Linear Delay Diversity Scheme:** The simplicity of the scheme along with a substantial increase in the system's performance is the primary motivation behind implementing this scheme. Firstly, the signal from both the relays is transmitted without any changes to the pilots and the user data, which is in contrast to other complex schemes. With most of the Space Time/Frequency Codes, a modified version of pilots and/or data is transmitted from at least one of the relay stations. Secondly, the relative delay can be either caused inherently, in the case where there is no timing advance (TA) implemented or artificially in the channel model, to exploit full diversity. Thirdly, the receiver performs exactly the same procedures without any modifications, just as if it were for a single relay system, since it receives one combined signal which is viewed as transmitted over a single channel with virtually larger delay spread rather than two channel links with a smaller delay spread. Finally, the linear delay diversity scheme is expected to perform best in case of poor Line-of-Sight (LoS) scenario cases which is relevant to urban environment conditions.



**Demerits of Linear Delay Diversity Scheme:** However the simplicity of the linear delay diversity scheme comes along with a serious performance-degrading factor, especially when there is an inherent relative delay between the two links. When implementing a linear delay diversity scheme, basically two scenarios can arise depending upon the relative delay length between the two relays. In OFDMA and SC-FDMA, the concept of cyclic prefix is utilized in order to reduce the Inter-Symbol-Interference (ISI) with a condition that the cyclic prefix length should be greater than or equal to the channel delay spread. This very condition of cyclic prefix length acts as a performance limiting factor for a linear delay diversity scheme as well. *Figure 3.4* describes the first scenario when the combined length of linear delay and the actual delay spread of channel is less than the cyclic prefix length. The performance in terms of SNR is an increasing function of linear delay introduced till the sum length is less than or equal to the cyclic prefix length, after which the performance degrades significantly for a linear delay diversity scheme with increasing delay.

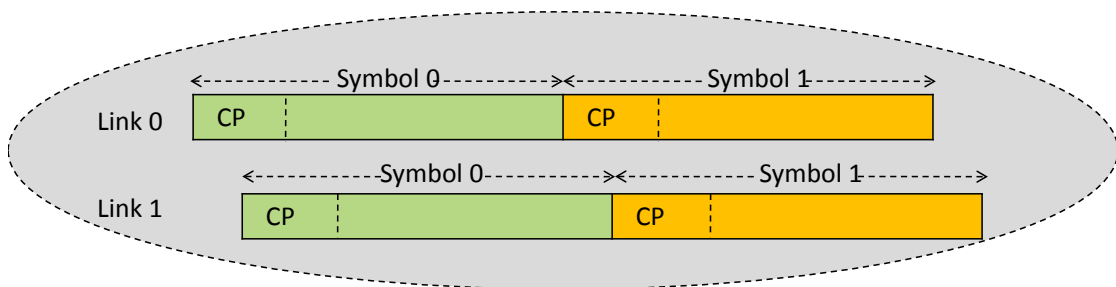

FIGURE 3.4: Delay Diversity Scheme Scenario 1: No ISI

The second scenario of performance degradation is illustrated in *Figure 3.5*. The system experiences ISI due to an overall delay spread greater than the cyclic prefix length.

In addition, the diversity scheme also suffers from the timing errors in channel estimation of the two relays. Therefore the combined channel estimate seems to be faded, which may result in degrading the performance of the diversity schemes. However, [18] has provided efficient solution to this problem of timing errors in channel estimation of cooperative relays.

Henceforth, the constraint coming with delay diversity scheme encourages the implementation of a more elegant, complex and constraint-free diversity scheme on

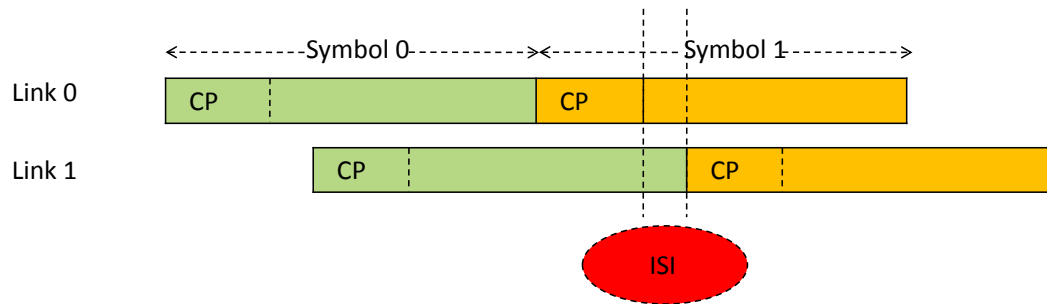

FIGURE 3.5: Delay Diversity Scheme Scenario 2: ISI Exists

the platform, which would be expected to perform better than a linear delay diversity scheme irrespective of environment. The next section describes a complex but more productive scheme described as the Distributed Alamouti Scheme and also points out the associated challenges for successful implementation of the scheme at system level.

### 3.3.2 Distributed Alamouti Scheme

the Alamouti Space-Time Coding scheme is considered as the only space-time code that provides full rate and full diversity in MIMO Communication Systems. The extension of the Alamouti Scheme to a distributed system of relays is defined as a Distributed Alamouti Scheme. Such a distributed Alamouti Scheme has been studied in the past demonstrating significant performance enhancement in terms of SNR [19], therefore in order to exploit significant diversity gains and to provide solutions to challenging tasks involved, the distributed Alamouti scheme is implemented on the platform. The fundamental structure of the distributed Alamouti scheme remains similar to that in a MIMO system with a Orthogonal Space-Frequency Code being generated at the two relays instead of at the two antennas of the same user. The Alamouti precoding matrix for a distributed system is indicated below:

$$\begin{bmatrix} X_0 & -X_1^* \\ X_1 & X_0^* \end{bmatrix}$$

\* indicates the conjugate of a symbol, 1<sup>st</sup> column corresponds to the frequency-domain symbol for relay 0 and 2<sup>nd</sup> column corresponds to relay 1. The row indicates subcarrier index.

As can be seen in the matrix, the symbols transmitted from the second relay are modified in order to construct an orthogonal code. The combination of this orthogonality in the Alamouti precoding matrix and the two independent fading paths effectively exploits the macro-diversity in the multipath channel and quite significantly improves the system's performance on the whole. At the receiver, a combined signal from the two relays is received which is represented by the following expressions in the frequency-domain. The subscript in all the terms represents the subcarrier index.

The received signal at subcarrier 0:

$$Y_0 = X_0 H_0^0 + (-X_1^*) H_0^1 + Noise \quad (3.1)$$

Where Y is the received symbol, X is the symbol transmitted by relays,  $H_0^0$  and  $H_0^1$  are the Channel Transfer Function (CTF) at subcarrier 0, for the link between relay 0 and the destination and relay 1 and the destination respectively. The first expression on the right is basically the received signal due to relay 0, the second expression on the right side is similarly the received signal due to relay 1 and Noise indicates the Additive White Gaussian Noise (AWGN) at the receiver.

The received signal for subcarrier 1:

$$Y_1 = X_1 H_1^0 + X_0^* H_1^1 + Noise \quad (3.2)$$

Once the combined symbols corresponding to each subcarrier are extracted, and then the last, but the most crucial step of the distributed Alamouti scheme is implemented, which is described as Alamouti receiver combining. In order to correctly estimate the transmitted symbol for each subcarrier, the Alamouti receiver combining is performed between every two consecutive symbols in the frequency-domain in a pre-defined manner. For clear understanding, the Alamouti receiver combining between the symbols received at subcarrier 0 and subcarrier 1 for estimating the first two transmitted symbols is illustrated by the following expressions:

The estimation of the symbol transmitted by the source corresponding to subcarrier 0 is given by:

$$\hat{X}_0 = Y_0 \hat{H}_0^{0*} + Y_1^* \hat{H}_0^1 \quad (3.3)$$

The estimation of the symbol transmitted by the source corresponding to subcarrier 1 is given by:

$$\hat{X}_1 = Y_1 \hat{H}_1^{0*} - Y_0^* \hat{H}_1^1 \quad (3.4)$$

$\hat{H}$  indicates the estimates of the channel.

**Main Challenge for Successful Implementation of Alamouti Scheme in a Distributed System:** The fundamental steps performed for the distributed Alamouti scheme are similar to that of are normal scheme in MIMO systems. However, the major hurdle in successful implementation of the Alamouti scheme in a distributed system of two relays is to obtain separate channel estimates of the two individual channel paths i.e. from relay 0 to the destination and relay 1 to the destination. As can be seen in *Equation 3.3* and *Equation 3.4*, it is required to have separate channel estimates for both the paths in order to perform Alamouti receiver combining. The procedure of channel estimation, as described in *Chapter 2*, shows that the main requisite for correct channel estimates is to have orthogonality between the reference signals of the two links.

During the thesis work, one of the main contributions from the research perspective is to devise an effective channel estimation procedure for a distributed system of relays to enable distributed Alamouti scheme. The next section describes the procedure developed for this purpose in detail.

### 3.4 Channel Estimation for Cooperative Relays

This section describes the main requirement for extracting separate channel estimates from a combined channel estimate at the receiver to facilitate Alamouti receiver combining. Based on the requirement, the section then discusses the technique developed and implemented during the thesis work.

### 3.4.1 Requirement for Separate Channel Estimates

As described in the previous section, in order to perform Alamouti receiver combining, it is required to extract separate channel estimates for both the channels from relay 0 and relay 1 to the destination. However this is possible only when the reference signals of the two channels do not interfere with each other as they are required for correct channel estimation at the receiver. Since they are transmitted from both the relays at the same time and on the same RBs, therefore the best possible solution is to have the reference signal of one relay orthogonal to the reference signal of the other relay within the same set of subcarriers. In this way, they will have a zero cross-correlation and can be easily separated at the receiver.

For the system developed in this thesis work, the UEs act as the two relays and the destination is an eNodeB. Therefore the two links from relay 0 to destination and from relay 1 to destination forms an uplink phase. As mentioned in *Chapter 2*, for the uplink channel, DRS is used for correct channel estimation at the receiver, which means they are required to be orthogonal to each other. One possible method is to perform FDM of the RSs within the same set of subcarriers, which would ensure orthogonality between the RSs of the two relays. But using FDM within the same set of subcarriers would reduce the RS sequence length which in turn decreases the number of the different RS sequences available because the length of base sequence decides the total number of sequences available. Perhaps this is not the best possible method for a low bandwidth system.

The motivation is to utilize the maximum possible RS sequence length available along with providing orthogonality between the RSs of the two relays. This led to a close study of the type of sequence generator for DRS in uplink which are ZC sequences as mentioned in *Chapter 2*. These sequences have a very unique property of having zero cross-correlation of any ZC sequence with its cyclic-shifted version [20, 21], which means that if the RSs of one of the relays has a cyclic-shifted version of RSs of the other relay, then they can be fully orthogonal to each other even on the same set of subcarriers. Therefore this technique is developed for obtaining separate channel estimates in a cooperative system of relays.

### 3.4.2 Extraction of Separate Channel Estimates

In OFDMA or SC-FDMA, the channel delay spread is of finite length which results in a finite channel impulse response. The cyclic-shift between the RSs of the two relays, therefore should be greater than the channel impulse response time, so that there is a sufficient time-gap between the channel impulse response of the two channels for extracting two separate channel estimates. In LTE, 12 equally spaced cyclic time-shifts are defined for DRS, which mean 12 separate channel estimates can be obtained using the same set of subcarriers. However since the system developed in the thesis has only two relays, therefore the maximum cyclic time-shift is utilized for better channel estimation. The maximum cyclic time-shift corresponds to a phase shift of  $\pi$  in the frequency domain. The extraction of separate channel estimates is facilitated by procedures, both at the transmitter and the receiver.

#### Steps at Transmitter

In the system, the DRS at the relay 0 is transmitted in a standard format as for any other uplink channel, but the DRS for relay 1 is modified before transmission. A simple way to generate a cyclic time-shift to the DRS at relay 1 with respect to the DRS at relay 0 is to introduce a phase shift in the frequency-domain before adding the cyclic prefix to the OFDMA/SC-FDMA symbol. The addition of a phase shift before adding the cyclic prefix is a very crucial step, as it ensures the shift introduced is cyclic in the time-domain. Therefore a phase shift of  $\pi$  generates a maximum time shift which is equal to half of the OFDM/SC-FDM symbol duration which is based on the phase shift property of fourier transform. The following expressions illustrate the DRS transmitted at both the relays to introduce orthogonality between them:

$X_k$  is the RS at relay 0 for  $k^{th}$  subcarrier

$e^{j\pi k} X_k$  is the RS at relay 1 for  $k^{th}$  subcarrier

Thus the orthogonal DRSs are transmitted at relay 0 and relay 1, which facilitate extraction of separate channel estimates at the receiver corresponding to the DRS symbols in the uplink subframe.

#### Steps at Receiver

At the receiver, a combined signal is received from both the relays. The combined

time-domain DRS symbol received at the destination is given by:

$$y(t) = x^0(t) \odot h^0(t) + x^1(t) \odot h^1(t) \quad (3.5)$$

where  $y(t)$  is the received time-domain DRS symbol,  $x^0(t)$  is the DRS transmitted by relay 0,  $h^0(t)$  is the channel impulse response of the link from relay 0 to destination.

Similarly,  $x^1(t)$  is the DRS transmitted by relay 1,  $h^1(t)$  is the channel impulse response of the link from relay 1 to destination.

$\odot$  represents the circular convolution.

However since the DRS symbol transmitted from relay 1 is a cyclic shifted version of the DRS symbol from relay 0, therefore *Equation 3.5* can be expressed in the following form:

$$y(t) = x^0(t) \odot h^0(t) + x^0(t - \tau) \odot h^1(t) \quad (3.6)$$

Where  $\tau$  is the time-shift corresponding to the phase shift introduced at relay 1.

Using the property of circular convolution, the received signal is expressed as:

$$\begin{aligned} y(t) &= x^0(t) \odot h^0(t) + x^0(t) \odot h^1(t - \tau) \\ &= x^0(t) \odot (h^0(t) + h^1(t - \tau)) \end{aligned} \quad (3.7)$$

Therefore, at the destination, a combined channel estimate is first extracted for a DRS symbol which is illustrated in *Figure 3.6*

As can be seen in the figure, the channel estimates for the two relays are clearly visible, separated by half of the symbol size. Therefore, separate channel estimates are then extracted in the time-domain as shown in *Figure 3.7* and *Figure 3.8*.

Once the separate channel estimates corresponding to the DRS symbol are extracted for both the links, then the channel estimates for the remaining symbols are obtained as described in *Chapter 2*. Hence using these separate channel estimates, the Alamouti receiver combining is performed and macro-diversity is exploited in the system.

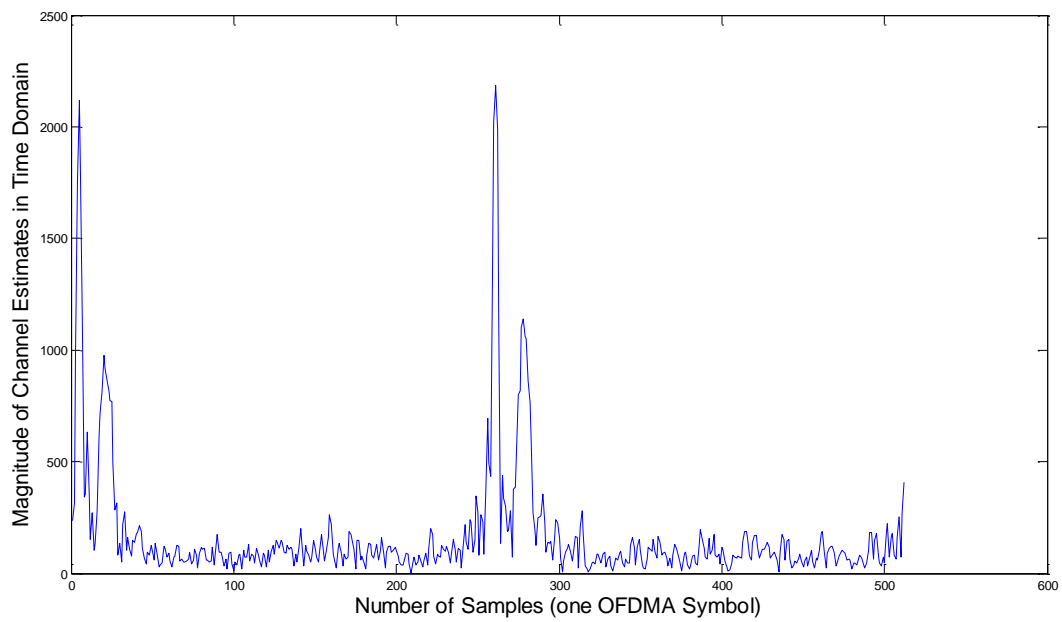

FIGURE 3.6: Combined Channel Estimate in the time-domain

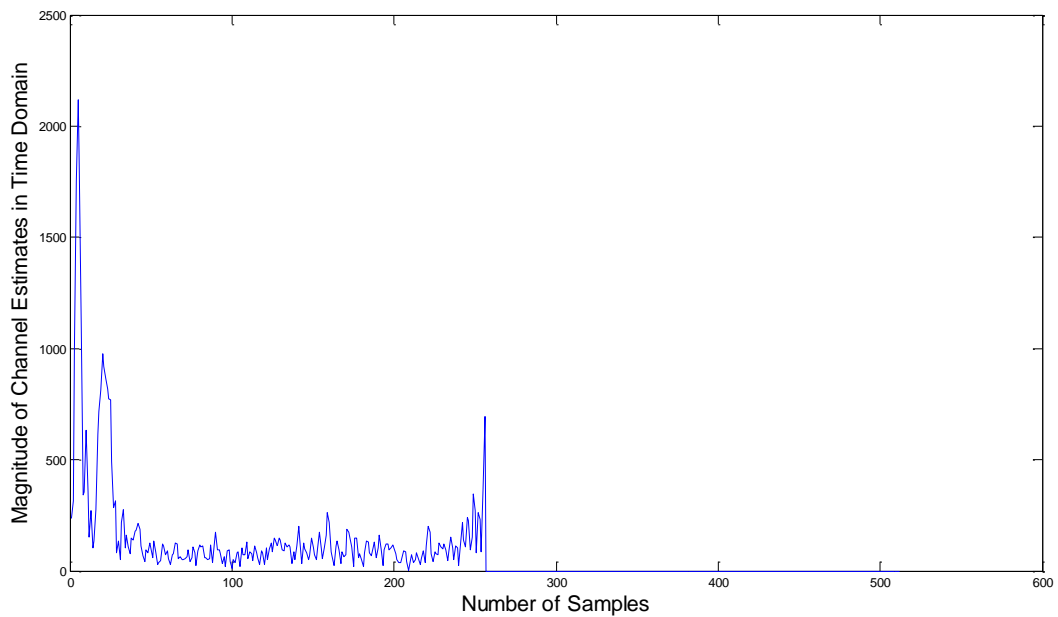

FIGURE 3.7: Channel Estimate in the Time-domain for Relay 0

The complete graphical representation of the entire process of having combined channel estimates in the frequency-domain at the receiver, then transforming it to the time-domain, separating the individual channel estimates in the time-domain, converting them back to the frequency-domain and estimating it for the remaining



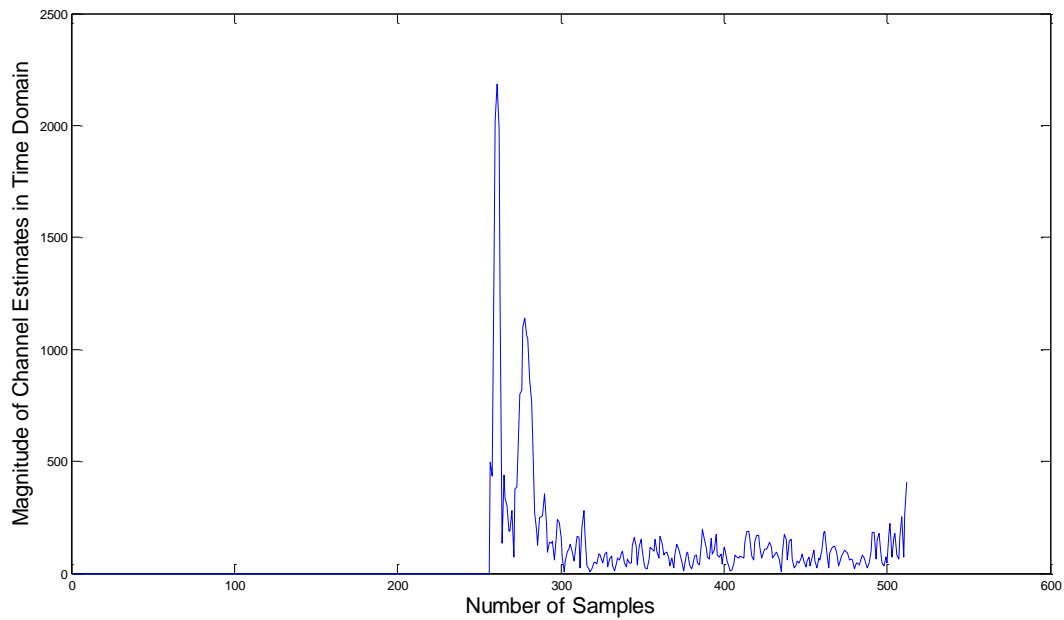

FIGURE 3.8: Channel Estimate in the Time-domain for Relay 1

symbols of the subframe is given in *Appendix A*.

### 3.5 Summary

This chapter has explicitly described the procedures which are specific to the cooperative communication system via a distributed array of two relays and has provided solution to the problem of extracting channel estimates for the two users transmitting on the same set of RBs, which can also be extended to a multi-user non-cooperative system. The system described in this chapter is further developed in the next chapter with the implementation of HARQ schemes and then the two diversity schemes described in this chapter will be compared and analyzed in *Chapter 5*.

# Chapter 4

## Hybrid-ARQ for Cooperative Schemes

The HARQ protocol with incremental redundancy accounts for one of the most crucial aspect in 3GPP LTE and all advanced mobile standards for providing strong robustness against a fading channel [22]. Therefore in addition to the diversity gain provided by the cooperative scheme in a relay network, further scope for improving the end-to-end performance is provided by the implementation of a HARQ scheme with incremental redundancy. Henceforth, this chapter intends to provide efficient retransmission schemes which further improve the overall error rate of the system along with the minimum possible delay for information transfer from source to destination. The chapter formulates two different HARQ schemes that will be quantitatively analyzed in *Chapter 5*.

### 4.1 Bases for HARQ Scheme in Cooperative Communication

As briefly discussed in *Chapter 2*, the HARQ with incremental redundancy is based on combining the first transmitted packet and its retransmitted duplicates with increased redundancy. A single-hop communication retransmits the packet with an incremental redundancy when a NACK is sent from destination to source, which is the most generic case for HARQ retransmissions. However for the system described in *Chapter 3*, the implementation of HARQ retransmissions becomes much more

complex as there are four independent links which correspond to retransmissions between four pairs of transmitter and receiver. For such relaying system, most of the studies in the past have resorted to broadcasting of NACK from the destination to all nodes which result in retransmission from the source as well as the relay stations [23, 24]. Such retransmission schemes are found more useful in case of selective relaying rather than cooperative communication via relays.

The motivation here is to improve the overall system performance by the combination of appropriate cooperative methods along with the most efficient HARQ schemes rather than by utilizing one of them individually. Therefore, in order to devise the best possible solution, the three main performance driving factors should be taken into account: end-to-end throughput, overall delay and the block error rate (BLER) at the destination. The criterion for a system design is to have maximum throughput with reduced delay and minimum possible BLER. In a cooperative system of distributed relays, there is a need for Smart HARQ (SHARQ) schemes which is able to exploit the following benefits of a cooperative system in addition to its inherent performance enhancing capability.

1. The cooperative system of distributed relays establishes an end-to-end link in two phases, phase 1 being from source to relays and phase 2 is from relays to destination, with phase 2 establishing the link even when just one relay decodes the signal. The HARQ scheme should therefore be devised in a smart way which initiates retransmissions from source only when signal is decoded incorrectly at both the relays.
2. In phase 2 of cooperative system, error performance is expected to be better when both relays forward and exploit the macro-diversity. If the destination decodes the signal incorrectly, then two possibilities exist due to the existence of cooperative relays: One is to have retransmission in phase 2 and the other is to have retransmission in phase 1 (if retransmissions in phase 1 are not exhausted).

Based on these possibilities, two Smart HARQ (SHARQ) schemes are devised for the cooperative system. They are described with the help of all scenarios in *Section 4.2*.

## 4.2 Smart HARQ Schemes (SHARQ)

The two schemes described here are based on the principal condition that source initiates retransmissions only when it receives NACK from both the relays. The source does not retransmit when it receives a NACK from just one of the two relays in the system, it rather waits for an ACK or a NACK from the other relay and if it receives ACK from that relay, it does not retransmits. In the alternative scenario, when the source receives ACK from both the relays, it automatically sets the retransmissions counter to the maximum number so that phase 1 is shut for transmission of that particular packet. Based on these principal conditions, SHARQ scheme I and SHARQ scheme II are developed.

### 4.2.1 SHARQ Scheme I

In phase 2 of a system, two states can exist depending upon the decoding at the two relays in phase 1. If both relays decode correctly, then cooperative communication takes place in phase 2, otherwise when only one of the two relays decode correctly, its a single relay forwarding scenario. SHARQ I is based on having retransmissions in phase 2 irrespective of the state of the system, which means if the final destination decodes incorrectly, the scheme initiates retransmissions in phase 2 between forwarding relay(s) and destination and continue till the destination decode correctly or till maximum number of retransmissions is exhausted for phase 2. However when the retransmissions for phase 2 are used, then it demands retransmissions in phase 1 if the number of retransmissions were not consumed initially, but the scheme is smart in a sense that it does not demand retransmissions in phase 1 if already both relays were forwarding in phase 2.

### 4.2.2 SHARQ Scheme II

SHARQ scheme II is based on system aware retransmissions in phase 2. Contrary to scheme I, SHARQ II does not initiate retransmissions in phase 2 only on the condition if the destination decodes signal incorrectly. When the destination decodes incorrectly, it sends a NACK message to the forwarding relay(s), and it is at this stage that SHARQ II acts differently to SHARQ I. Instead of initiating retransmissions in phase 2 after receiving a NACK from destination, the relay(s)

instead send a NACK to the source and the source starts retransmissions if it had not exhausted the maximum number of retransmissions. Therefore SHARQ II is described as system dependent retransmission scheme.

The SHARQ scheme II aims to exploit cooperative communication in a better way than the SHARQ I and relies more on diversity gain for system performance enhancement. Retransmissions in phase 1 are favored rather than in phase 2 of the system since the probability of correctly decoding the signal at both relays is increased for this case which in turn results in cooperative communication in phase 2. With cooperative communication in phase 2, the error performance is expected to improve, however there might be an overall increased delay due to 2-hop transmission of NACK from destination to relay and then further to source. *Which scheme is better than the other?* Perhaps it is qualitatively not possible to compare the performance of two schemes and therefore the quantitative results for both the schemes are analyzed in *Chapter 5* to provide an answer to this question.

# Chapter 5

## Simulator Description and Performance Analysis

All the previous chapters describing numerous procedures constitute the platform's development work, which is a pre-requisite to run a system level simulator for cooperative communication via distributed relays. This chapter now describes the actual simulation environment that is created to obtain performance measuring results for all possible scenarios. It gives an overview of the entire simulator, specifically describes the channel modeling and then lists the simulation parameters used for generating results in the next chapter. This chapter also provides the results of all the scenarios (mentioned in the previous chapter) in terms of BLER for individual phases, overall BLER and end-to-end throughput of a cooperative system of distributed relays against discrete values of SNR. However the primary purpose of the chapter is to perform explicit comparisons between all the relevant scenarios and indicate the favorable ones.

The chapter shows the comparative analysis between the three relaying scenarios developed without HARQ implementation: Single Relay, Delay Diversity and Distributed Alamouti. Moving ahead, the results from SHARQ schemes are then compared with a no HARQ implementation for all the relaying scenarios. Based on all this comparisons, the chapter points out the best possible scenario for implementation in a real system.

## 5.1 Simulator Overview

Till now, the entire distributed system has been described in terms of a source, a destination and two relays. However, the first and foremost step of developing a simulator is to define these nodes in terms of eNodeB(s) and/or UE(s), since the standard defines only the downlink and uplink phase depending on the nodes. *Figure 5.1* illustrates a complete system indicating all the phases involved. As indicated in the figure, phase 1 between the source and the two relays is a downlink, and phase 2 between the relays and the destination is an uplink based on the nodes representation.

The primary purpose of any system level simulator is to replicate the actual real-time scenario in the best possible way. The system level simulator created during the thesis is not far away from the real-time scenario, since it is developed on the same firmware as used in real-time demonstrators of OpenAir Interface. The simulator is developed for a uni-directional transmission of information from source to destination. Although the two-way communication case is closest to a real-time network, but being in the nascent stage of investigating cooperative schemes made it not so imperative to begin with the exact real-time scenario. The focus is to derive results for the schemes developed, carry out extensive comparative analysis and point out the best possible scenario for demonstration in a real-time network.

The simulator is developed keeping in mind the flexibility that it should offer in order to implement the two diversity schemes along with a single relay case for the purpose of comparison. In addition, the two SHARQ schemes described in the last chapter are also implemented in the same simulator itself. In total, the simulator offers all the nine scenarios mentioned below:

### I. Without HARQ

1. *Single Relay case*
2. *Delay Diversity Scheme*
3. *Distributed Alamouti Scheme*

### II. With SHARQ I

1. *Single Relay case*

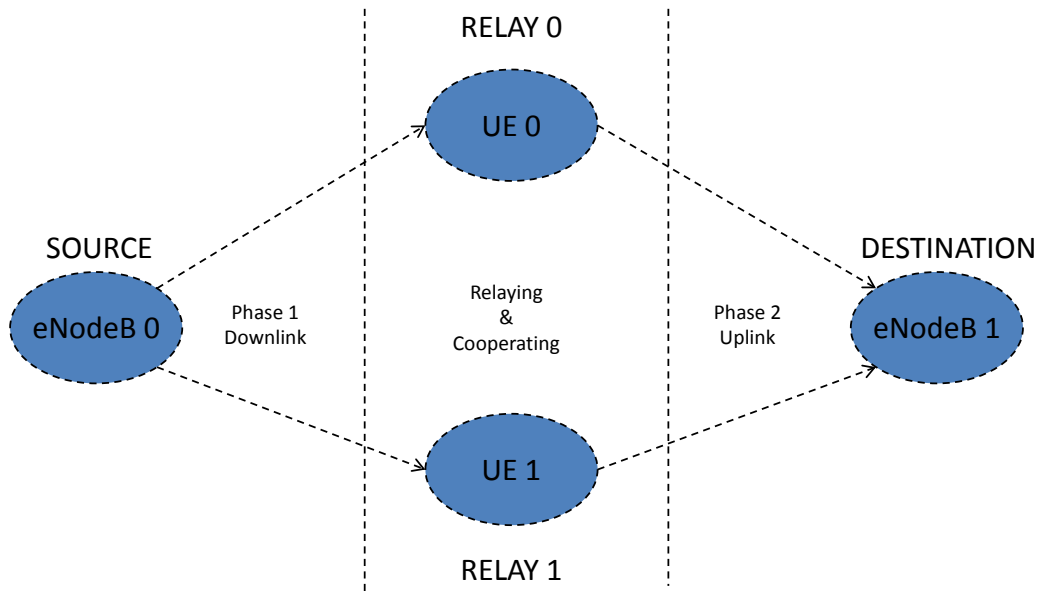

FIGURE 5.1: Distributed System Representation

2. *Delay Diversity Scheme*
3. *Distributed Alamouti Scheme*

### III. With SHARQ II

1. *Single Relay case*
2. *Delay Diversity Scheme*
3. *Distributed Alamouti Scheme*

## 5.2 Channel Modeling

For artificial reverberation of the multipath channel as in a real environment, the simulator uses a Tapped-Delay Line (TDL) channel which follows a Ricean model [25]. The emulation model also has a low-complexity geometry based channel that uses a reduced set of taps for representing the different paths [26]. The channel is basically generated in two steps: First an algorithm is performed to generate a channel state vector representing the reduced set of paths and secondly the taps



are sinc-interpolated to yield a Channel Impulse Response (CIR). The first step is represented by the following expressions:

$$\mathbf{a}^{(n)} = \sqrt{\nu}\mathbf{a}^{(n-1)} + \sqrt{(1-\nu)}\sqrt{\left(\frac{k'}{2}\mathbf{amps}\right) \odot \mathbf{g}} + \sqrt{(1-\nu)}\Theta\sqrt{(1-k')} \quad (5.1)$$

$$k' = \frac{1}{(1+K)} \quad (5.2)$$

Where  $\mathbf{amps}$  is the linear amplitude of taps,  $\mathbf{K}$  is linear ricean factor,  $\nu$  is the forgetting factor between 0 and 1 which affects the correlation between the blocks,  $\mathbf{g}$  belongs to a set of normalized complex variables,  $\mathbf{n}$  indicates recursive steps and  $\Theta$  is a vector where first entry is a norm one complex scalar and rest are zeroes.

The second step of yielding CIR is indicated by the following equation:

$$h(m) = \sum_{l=0}^{N_p-1} a[l] \text{sinc}(m - F_s(l + \beta)\Delta\tau_d - \frac{F_s}{2}\tau_{max}) \quad (5.3)$$

$$\Delta\tau_d = \frac{\tau_{max}}{N_p} \quad (5.4)$$

Where  $N_p$  is the number of channel paths,  $\tau_{max}$  is the parameter to set maximum allowable delay in the channel,  $F_s$  is the sampling frequency and  $\beta$  is a real number added to ensure that the envelope of  $h(m)$  is continuous.

The number of samples  $n$  required to represent the channel length in a band gap between  $-W$  and  $W$  is given by:

$$n = 2WT + 1 + \frac{\alpha}{\pi^2} \ln(4\pi WT) \quad (5.5)$$

Where  $\alpha = 2$  is used. According to [27], this expression is valid when channel is represented by sum of orthogonal functions. An extra delay of  $1\mu s$  corresponding to  $\tau_{max}$  is included for an additional channel length of

$$2W\tau_{max} = F_s \cdot 1 \cdot 10^{-6} \quad (5.6)$$

Therefore the total channel length is the addition of extra channel length to  $n$ .

<b>Parameters</b>	<b>Values</b>
Bandwidth Allocated	5MHz (25 RBs)
Maximum Transmission Bandwidth	4.5MHz
Downlink Resource Blocks	25
Uplink Resource Blocks	19
Number of Subcarriers	512
Useful Subcarriers	300
Subcarrier Spacing	15KHz
Sampling Frequency	7.68MHz
Simulation Window	1 Subframe
MCS (DL and UL)	1
Number of OFDM symbols per slot	6
Cyclic prefix length	128 samples
Number of Transmit Antennas	1
Number of Receiving Antennas	2
Ricean Factor	20dB

TABLE 5.1: Simulation Parameters

### 5.3 Simulation Parameters

This section lists the parameters specific to the simulations carried out for performance evaluation in the next section. Being LTE compliant platform, the parameter's values used are basically a subset of that defined in the 3GPP LTE release 8 specifications [7, 28, 29].

## 5.4 Results and Analysis of Relaying Scenarios without HARQ

One of the primary objectives of the thesis as defined in *Chapter 1* has been to extend the concept of transmit diversity schemes to a distributed system of relays. Having developed this concept during the thesis work, the last (but most important) question left to answer is how do they improve the system performance with respect to a single relay case and which of the two schemes developed is best. This section provides the answer with the meaningful plots illustrated here.

### 5.4.1 Downlink SNR vs Probability of Forwarding/Cooperation

*Figure 5.2* indicates the probability of forwarding at the relay station(s) in a single relay case and a two relays case developed for cooperative communication. In addition, it also shows the probability of cooperation when two relay stations exist. These probabilities are basically **(1 - BLER)** in phase 1 (downlink phase) of a relaying system. As can be seen from the figure, the two-relay case begins with an added advantage of having higher probability of correctly decoding the signal at one of the two relays and thus forwarding the signal to the destination. The two-relay system forwards with a 100% probability at an SNR of 3dB lower than the case of a single relay system. However in order to exploit the advantage of macro-diversity in phase 2 of the system, phase 1 (downlink) SNR should be relatively higher than that required for just forwarding in order to have cooperation. Therefore, the main conclusion that can be drawn from this plot is that the cooperative communication via distributed relays requires having a strong radio links in phase 1 of the system.

### 5.4.2 Uplink SNR vs Uplink BLER (phase 2)

*Figure 5.3* compares the performance of the delay diversity scheme and distributed alamouti scheme along with single-relay case in terms of BLER in phase 2 (uplink). In order to compare the pure diversity gain of the two schemes, the SNR in phase 1 is set to 8dB which ensures perfect decoding at both relays and therefore enabling

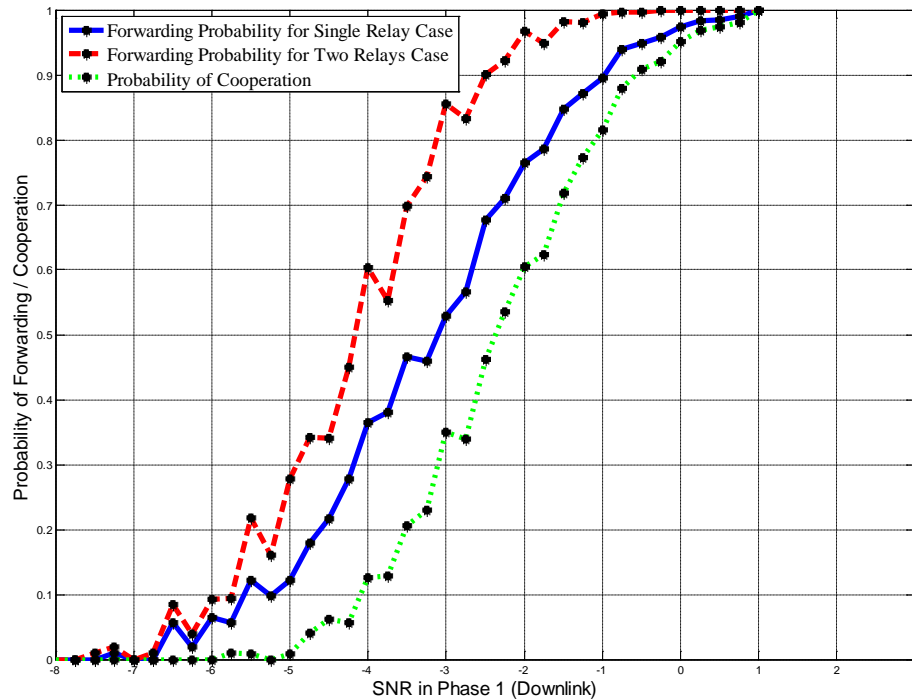

FIGURE 5.2: Downlink SNR vs Probability of Forwarding/Cooperation

cooperation between them. *Readers must also be aware that the total transmit power of the two relays in the two-relay case is scaled down to the transmit power of one relay in the single-relay case.* This comparison of phase 2 of the relaying system is required to illustrate the performance improvement by exploiting the macro-diversity due to cooperative communication which has been the first and foremost goal of this thesis work.

The above plot clearly indicates that the performance of phase 2 significantly improves when a transmit diversity scheme is applied using a distributed system of relays. As can be seen from the figure, around 2dB SNR gain (phase 2) is achieved when the distributed Alamouti scheme is applied, which is primarily the gain due to the macro-diversity of uncorrelated channel paths from the two relays to the destination. However when we compare the two transmit diversity schemes, we can conclude that the distributed Alamouti performs better even at low SNR values when compared to the delay diversity scheme.

One more interesting conclusion that can be drawn on the basis of last two plots is that for such distributed systems, phase 1 requires a better link as compared to

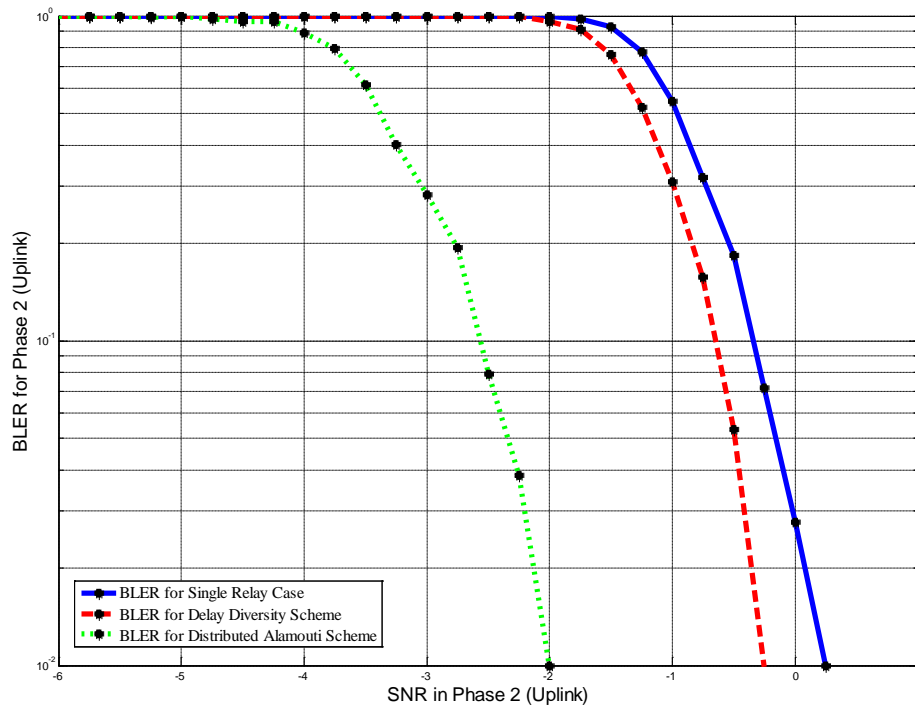

FIGURE 5.3: Uplink SNR vs Uplink BLER at 8dB Constant Downlink SNR

the link of phase 2. This meaningful conclusion is in accordance with the theory that if phase 1 is strong, only then the signal is decoded correctly at two relay stations after which transmit diversity schemes (cooperation) can be applied that require relatively low SNR values for correct decoding at the destination.

### 5.4.3 End-to-end BLER Performance of the System

The individual error performance for the two phases in the system was required to indicate the type of links required for phase 1 and phase 2. Having concluded that, there is a need to illustrate the end-to-end performance from source to destination, since in an overall system, the ultimate result that matters is at the destination of the complete link. This section describes the end-to-end performance of the system in terms of BLER against discrete values of SNR at phase 2 and for a constant value of 2dB SNR in phase 1. *Figure 5.4* shows the results for the three relaying schemes.

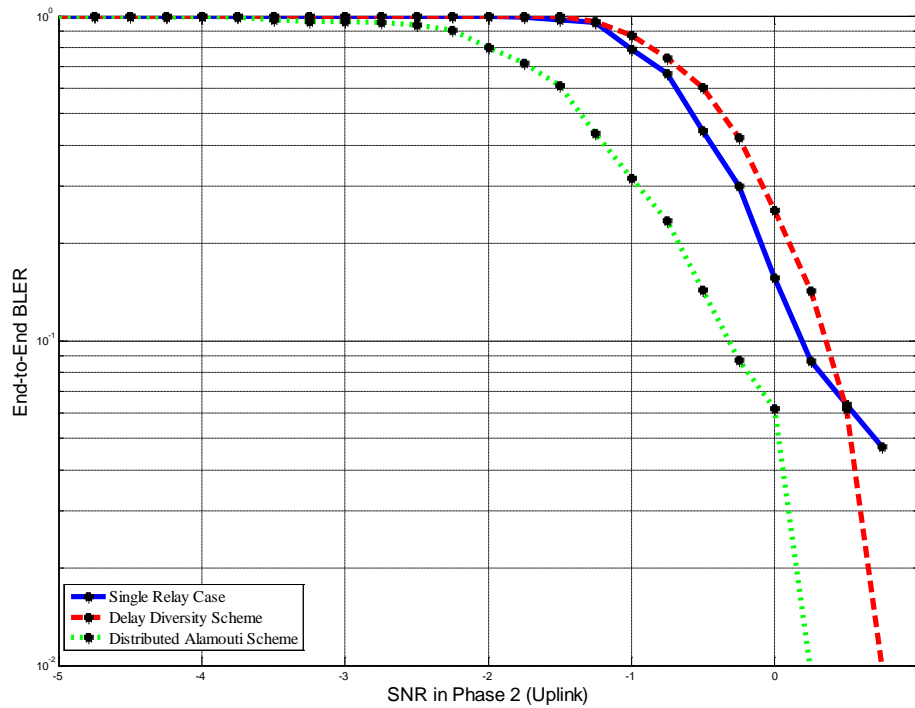

FIGURE 5.4: Uplink SNR vs end-to-end BLER at 2dB Constant Downlink SNR

The plot illustrates the end-to-end gain attributed to the diversity schemes used in comparison to a single relay case which advocates the implementation of cooperative communication via distributed system of relays. As can be seen the overall gain has decreased considerably compared to the pure diversity gain obtained in last plot which is attributed to a mixed scenario. Since the SNR value in phase 1 is not high enough to ensure 100% cooperation, therefore the gain has decreased considerably. But still, the distributed Alamouti gives the best performance among the three scenarios with single relay being the worst one. It can therefore be deduced that the end-to-end performance of a cooperative system performs quite better even at low SNR values.

## 5.5 BLER Comparison of SHARQ schemes with no HARQ Scenario

Moving step ahead in terms of system development with the implementation of SHARQ schemes, is a major advancement from the point of view of further performance enhancement. Although the cooperation provides considerable diversity gains, but the scope for improvement is always there which has been the main source of motivation for SHARQ schemes. This section therefore shows the results of SHARQ schemes as was described in *Chapter 4* and compares the results with a no HARQ case. The comparisons are made for all the three relaying scenarios individually first and finally one joint comparison is made which helps to deduce the best possible combination. The BLER for the SHARQ schemes is computed by dividing the errors in the last retransmission of HARQ by the number of trials in the first transmission.

### 5.5.1 BLER Performance Comparison for Single Relay Case

To start with, *Figure 5.5* compares the results of SHARQ schemes for the single relay case with the no HARQ case in terms of the end-to-end BLER of the system. SHARQ 1 and SHARQ 2 are exactly similar for the single relay case since the SHARQ 2 is designed in a way to exploit the cooperation of two relays. And since the single relay case does not employ cooperation, so the implementation is similar for both of them

As can be seen from the figure, the error performance significantly improves when SHARQ I/II is applied to the system of single relay. There is a major improvement of almost 5dB when a SHARQ scheme is applied to a system of single relay which is attributed to a combination of signal with incremental redundancy at the destination.

### 5.5.2 BLER Performance Comparison for Delay Diversity

For a delay diversity scheme, the performance of SHARQ I and SHARQ II are compared without the HARQ in *Figure 5.6*.

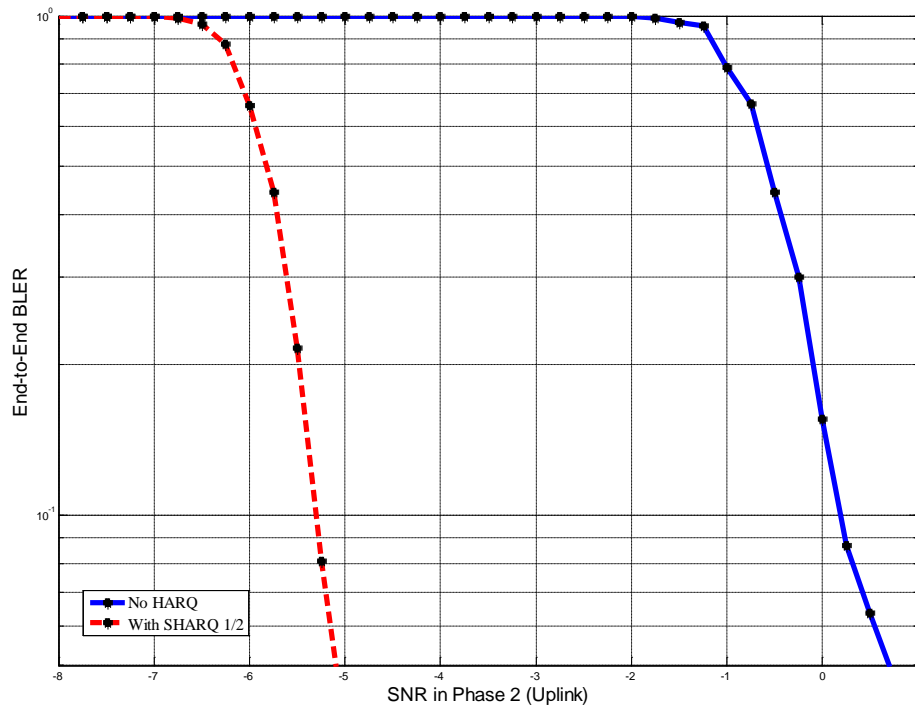

FIGURE 5.5: Uplink SNR vs End-to-end BLER for Single Relay Case

In this scenario, there is an error performance improvement of 5dB when SHARQ I is applied to the delay diversity scheme. The performance seems to be almost the same when SHARQ II is applied. This staggering performance enhancement illustrates the value of introducing HARQ to a distributed system of cooperative relays.

### 5.5.3 BLER Performance Comparison for Distributed Alamouti

Finally, SHARQ schemes performance for the distributed Alamouti scheme are illustrated in *Figure 5.7*.

The improvement here is also similar to that observed in the case of delay diversity and single relay system which points out that the SHARQ schemes developed for the relaying system are effective and stable for varying scenarios. Therefore having individually compared the performances of SHARQ schemes, it is interesting to



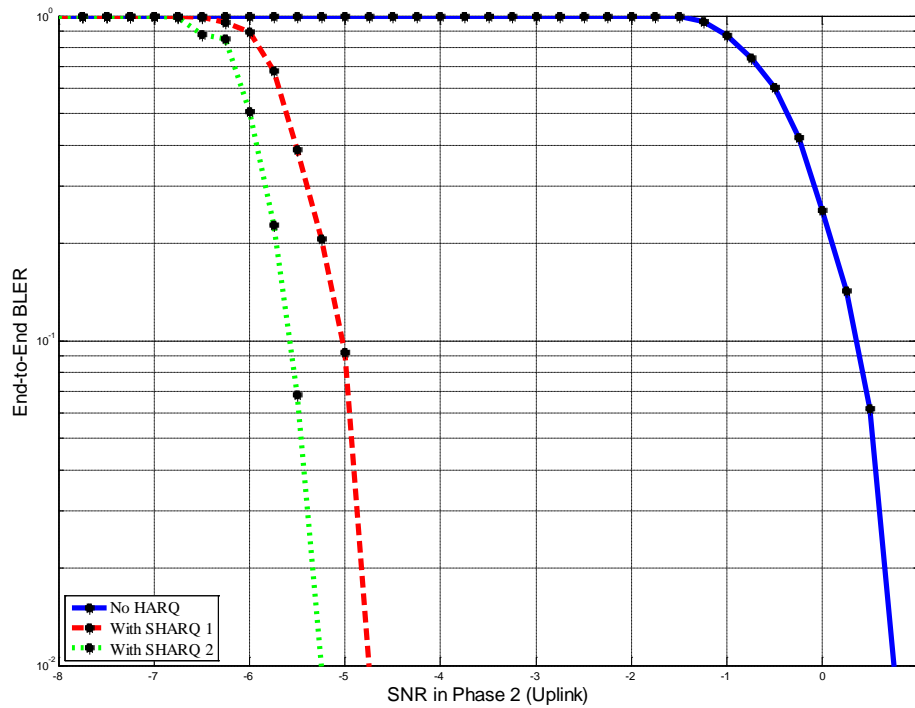

FIGURE 5.6: Uplink SNR vs End-to-end BLER for Delay Diversity

point out the best possible combination of relaying scenario and SHARQ scheme in the following section.

#### 5.5.4 BLER Performance Comparison for All Scenarios

Figure 5.8 gives a complete picture in terms of performance enhancement for all the possible scenarios that have been implemented during the thesis work.

All the three relaying scenarios with SHARQ schemes stand out in the figure from the viewpoint of BLER improvement which advocates the necessity of employing HARQ with incremental redundancy in any modern wireless system. However when comparing the scenarios in the region of HARQ schemes, there is one scheme that seems to be outperforming others. The distributed alamouti scheme implemented with SHARQ I gives the best performance in terms of end-to-end BLER of the system. It shows an improvement of almost 1dB SNR when compared with the counterparts and thus assist in concluding that it is the best possible combination for BLER performance among all the scenarios.

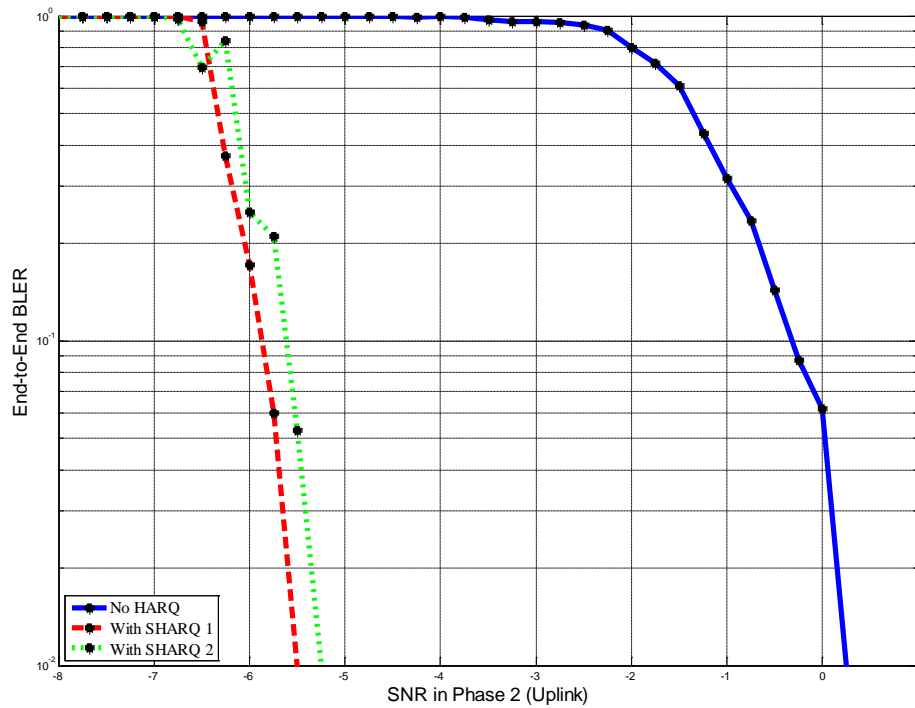

FIGURE 5.7: Uplink SNR vs End-to-end BLER for Distributed Alamouti

## 5.6 Throughput Comparison of SHARQ schemes with no HARQ Scenario

The BLER error rate of any system without the HARQ gives a clear picture of the system's performance, but when HARQ schemes are implemented in any system, the true performance of the system cannot be determined solely on the basis of end-to-end BLER. BLER may or may not indicate the real performance of the system in the case of HARQ implementation. Therefore the end-to-end throughput of a system gives more reliable information about its performance. The main reason for this difference in the reliability of BLER and the throughput is the inclusion of delay caused due to HARQ schemes in throughput computation. Equation 5.7 is the throughput expression for any relaying scenario without HARQ and Equation 5.8 indicates the same in case of any relaying scenario for any HARQ scheme.

$$\text{Throughput} = (1 - \text{BLER}) * (\text{Delay}(2\text{hop})) * (\text{TBS}) * (\text{Symbols}) * 100 \quad (5.7)$$

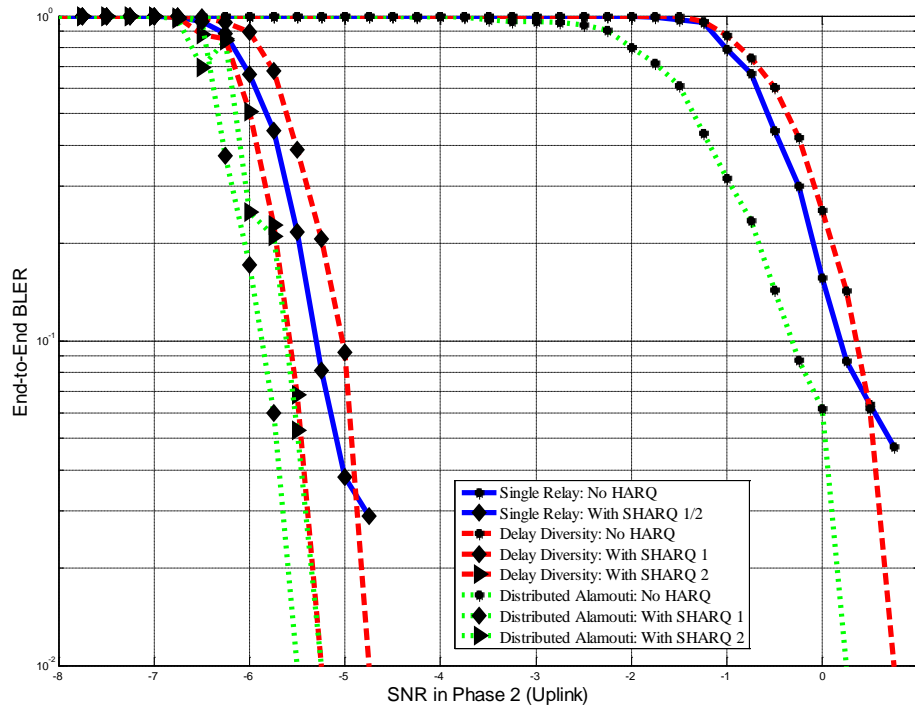

FIGURE 5.8: Uplink SNR vs End-to-end BLER for all Scenarios

Where Delay(2hop) is same for any relaying scenario, TBS is transport block size.

$$\text{Throughput} = (1 - \text{BLER}) * (\text{Delay}(\text{HARQ})) * (\text{TBS}) * (\text{Symbols}) * 100 \quad (5.8)$$

Where Delay(HARQ) is dependent on the number of retransmissions in a particular scheme, therefore this factor varies for different relaying scenarios and therefore helps the throughput to give the true performance of the system.

### 5.6.1 Throughput Performance Comparison for Single Relay Case

Figure 5.9 shows the throughput comparison for the single relay scenario with and without HARQ.

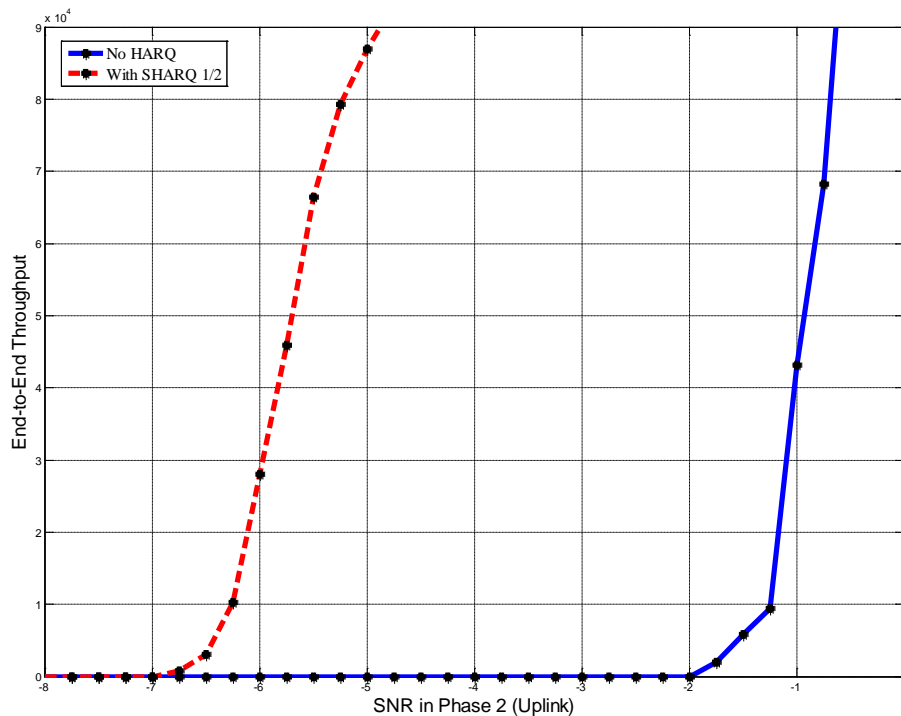

FIGURE 5.9: Uplink SNR vs End-to-end Throughput for Single Relay Case

The figure shows that even with the inclusion of the factor of delay due to HARQ, the throughput with the SHARQ scheme is better than without the HARQ. There is an improvement of almost 4dB in terms of SNR to obtain the same throughput. However the improvement for the BLER was 5dB for the same comparison which indicates the HARQ delay degrades the performance of the system by 1dB in terms of SNR.

### 5.6.2 Throughput Performance Comparison for Delay Diversity

The throughput performance for the delay diversity with SHARQ I, SHARQ II and no HARQ is compared in *Figure 5.10*.

Once again the performance seems to be better for the SHARQ schemes when compared with the no HARQ case. SHARQ II has a better performance than SHARQ I which is attributed to the HARQ delay and BLER of the schemes.

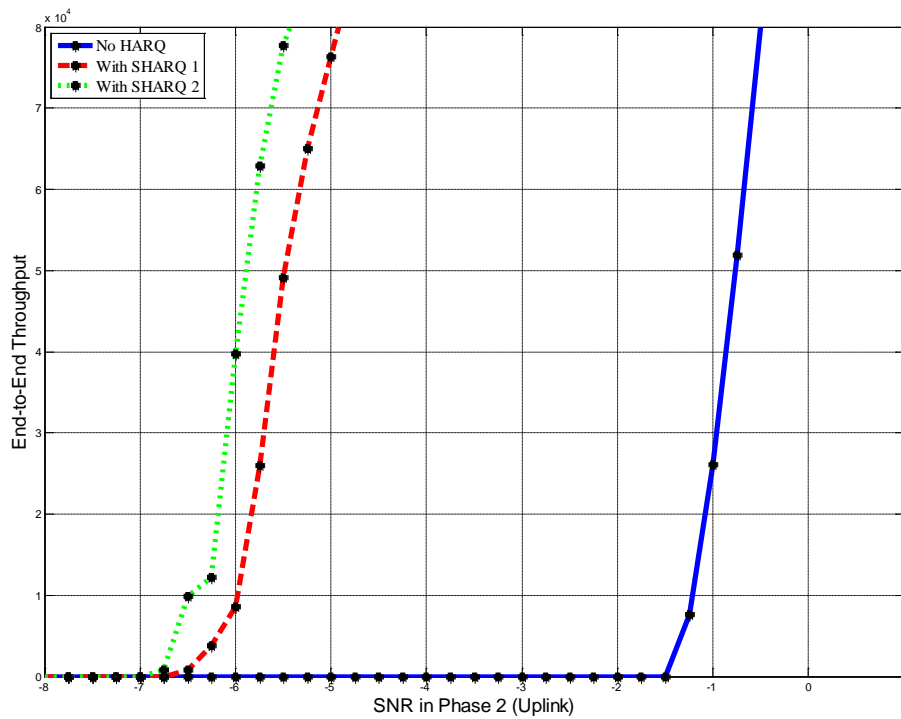

FIGURE 5.10: Uplink SNR vs End-to-end Throughput for Delay Diversity

### 5.6.3 Throughput Performance Comparison for Distributed Alamouti

For distributed Alamouti, *Figure 5.11* indicates the throughput performance for all the HARQ schemes.

As was the case with BLER performance, the throughput performance also shows a similar trend in the distributed Alamouti scenario. Almost 5.5dB of improvement is seen with the implementation of SHARQ I to distributed Alamouti scenario, with SHARQ II just a little behind.

### 5.6.4 Throughput Performance Comparison for All Scenarios

Finally, *Figure 5.12* compares the throughput performance for all the possible combinations of relaying scenarios and HARQ cases to assist most favorable one.

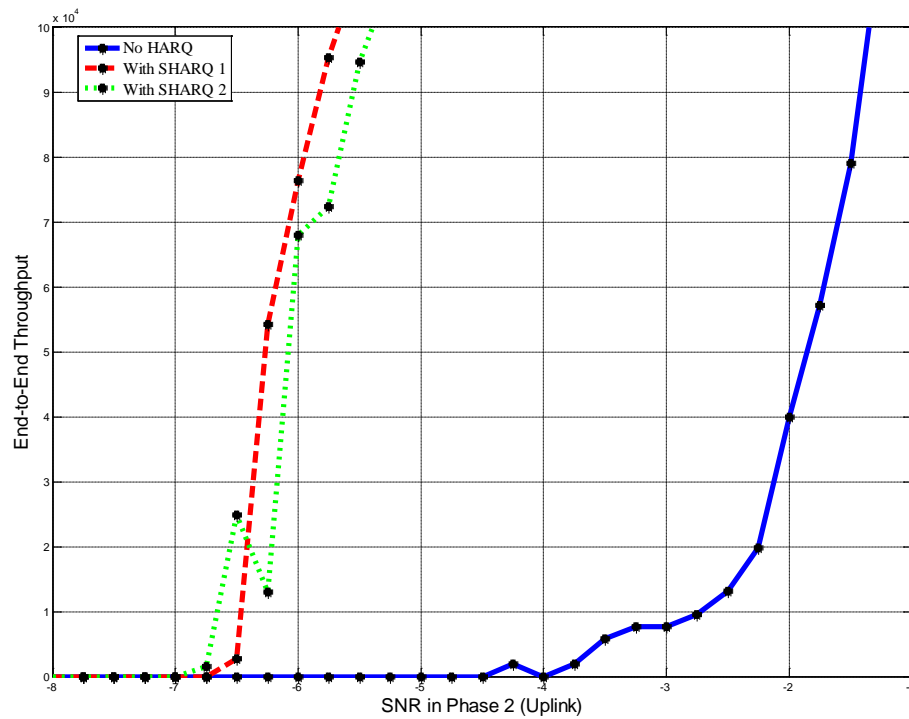

FIGURE 5.11: Uplink SNR vs End-to-end Throughput for Distributed Alamouti

The concluding remark that can be made from the figure is similar to that of BLER performance. It can be concluded that HARQ delay does not play a very significant role in degrading the system's performance for all the schemes indicated above. Therefore the Distributed Alamouti Scheme is concluded to be the most reliable mode of cooperation among two relays for significant performance enhancement as compared to a single relay case. The distributed Alamouti system performs exceedingly well when implemented along with the SHARQ schemes by decoding perfectly even at very low values of SNR on phase 2 (uplink).

The results illustrated during this chapter gives quite a clear indication of the significant gains obtained as a result of cooperative communication via a distributed system of relays along with HARQ schemes. These results solve the purpose of the work carried out during the period of thesis. However a more detailed performance analysis can be carried out for different channel conditions which might help in predicting the gains even in extreme conditions.

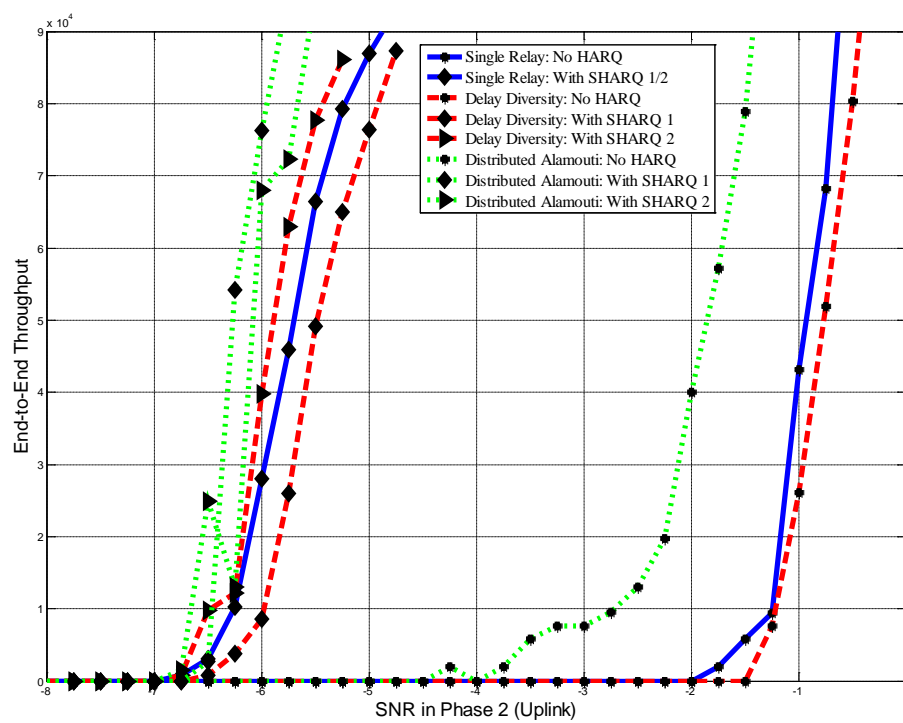

FIGURE 5.12: Uplink SNR vs End-to-end Throughput for all Scenarios

# Chapter 6

## Conclusions and Future Work

Cellular networks have always suffered from the problem of poor coverage and capacity to cell edge users. The distant nodes have to deal with a poor radio link quality which has been asking for reliable solutions to be implemented in IMT-Advanced systems. With this inspiration, the work carried out during the thesis developed a strategy based on the combination of relaying technology and cooperation among relays by implementing transmit diversity schemes derived from multiple antenna techniques in MIMO systems. In the beginning of the thesis work, various challenges were described for successful implementation of these strategies and during the course of the thesis, effective solutions were sought after to deal with these challenges and produce meaningful results.

The first requirement of introducing the relay stations is easily dealt with, as the UEs are basically used to represent the relays in this system and the eNodeBs for source and destination. From the learning point of view, this system is beneficial as it provided an opportunity to work on both the downlink and the uplink physical layer procedures. The primary idea of the thesis work is however the second objective of extending the transmit diversity schemes to a distributed system of relays. This issue has been covered in *Chapter 3* which provided the ways to effectively implement the transmit diversity schemes in a relay network. Talking about effective implementation brings the discussion to the third challenge of extracting separate channel estimates for performing Alamouti receiver combining. This is implemented by exploiting the inherent property of DRS's, which have zero cross-correlation with its cyclic-shifted version. Therefore using this property, orthogonal DRS for channel estimation are generated at transmitter and which are extracted as shown in *Appendix A*. Finally the last objective of developing an



entirely new HARQ scheme for such a cooperative relaying system is handled in *Chapter 4*. In fact, two efficient HARQ schemes described as SHARQ I and SHARQ II are developed during this thesis work.

Therefore the main objectives/challenges defined at the beginning of the thesis have been successfully dealt by providing more than just one option to most of them and then finally analyzing the performance of all scenarios from the results obtained in *Chapter 5*. Based on the performance analysis, the advantages of developing cooperative communication via a distributed system of relays proved to be in accordance with the anticipation.

### **Future Work**

Although the objectives defined are achieved in this thesis work, some work still needs to be done to bring this system to the next level of real-time implementation.

1. First and foremost, link adaptation needs to be introduced for this distributed system in order to make the system much more efficient from a resource utilization point of view.
2. As was mentioned, this system is a one-way communication link. But to implement in real-time network, the two-way link needs to be established for performing all the required procedures.

Therefore, with these steps, this distributed system of cooperative relays is expected to work in a real-time network and demonstrated using the same OpenAir Interface Platform.

# Appendix A

## Graphical Representation of Extracting Channel Estimates

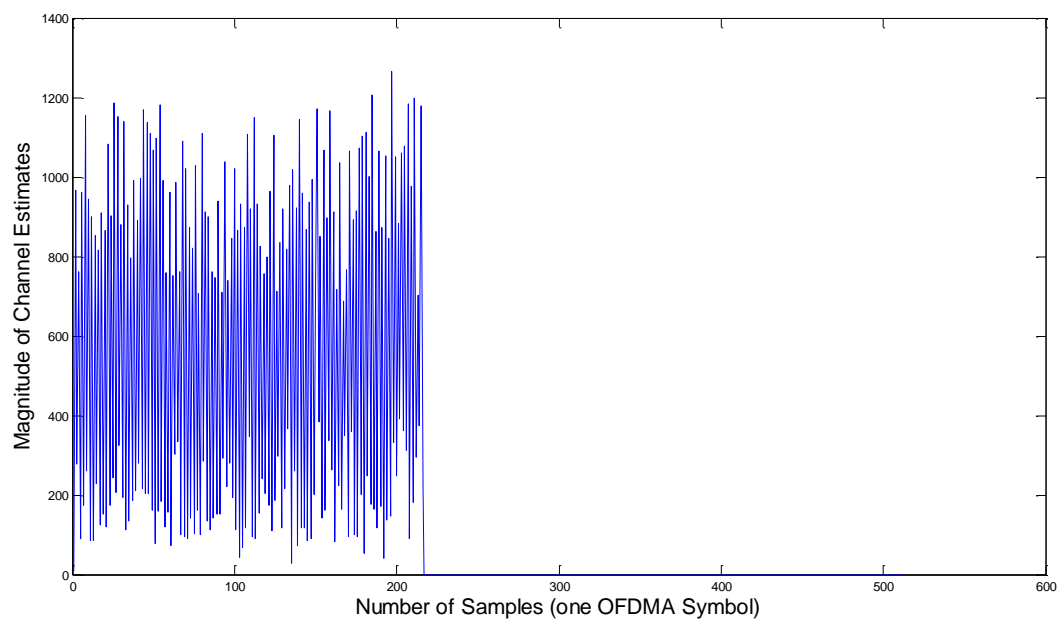

FIGURE A.1: Combined Channel Estimates in the Frequency-domain

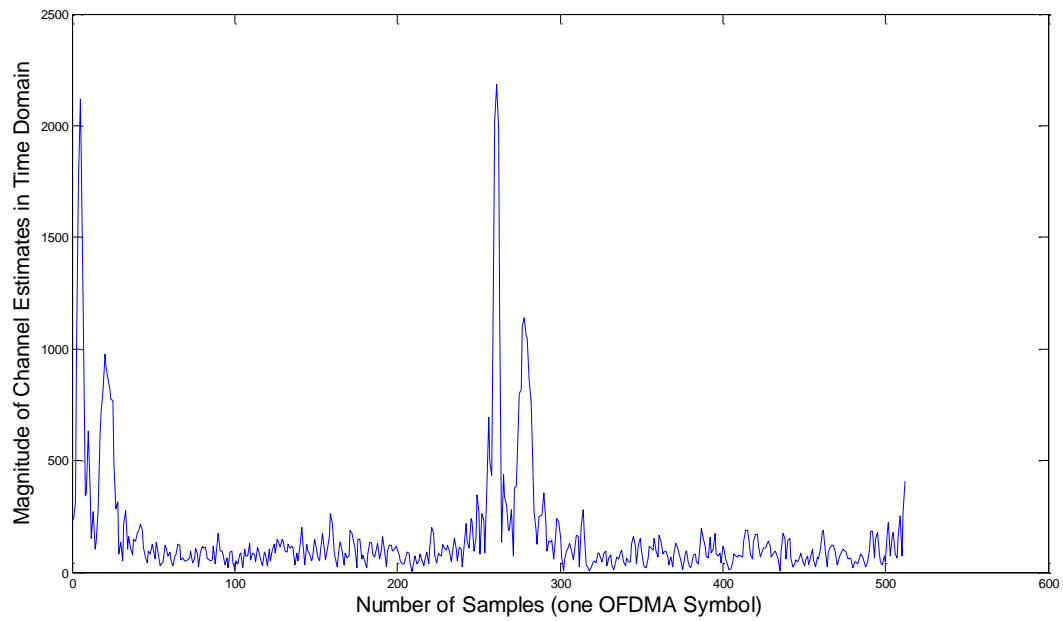

FIGURE A.2: Combined Channel Estimates in the Time-domain

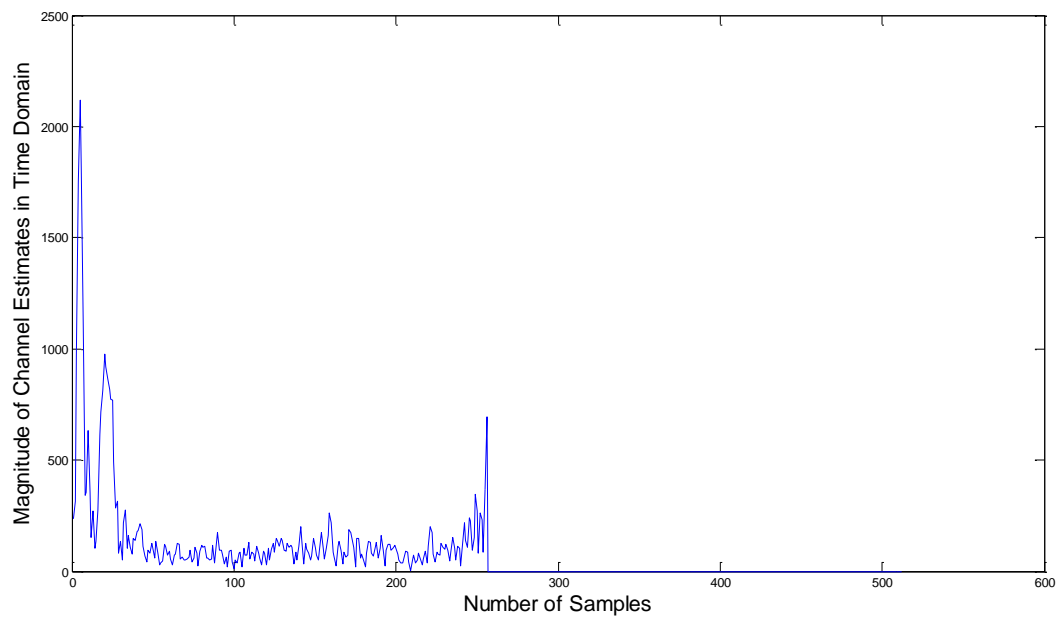

FIGURE A.3: Channel Estimates for Relay 0 in the Time-domain

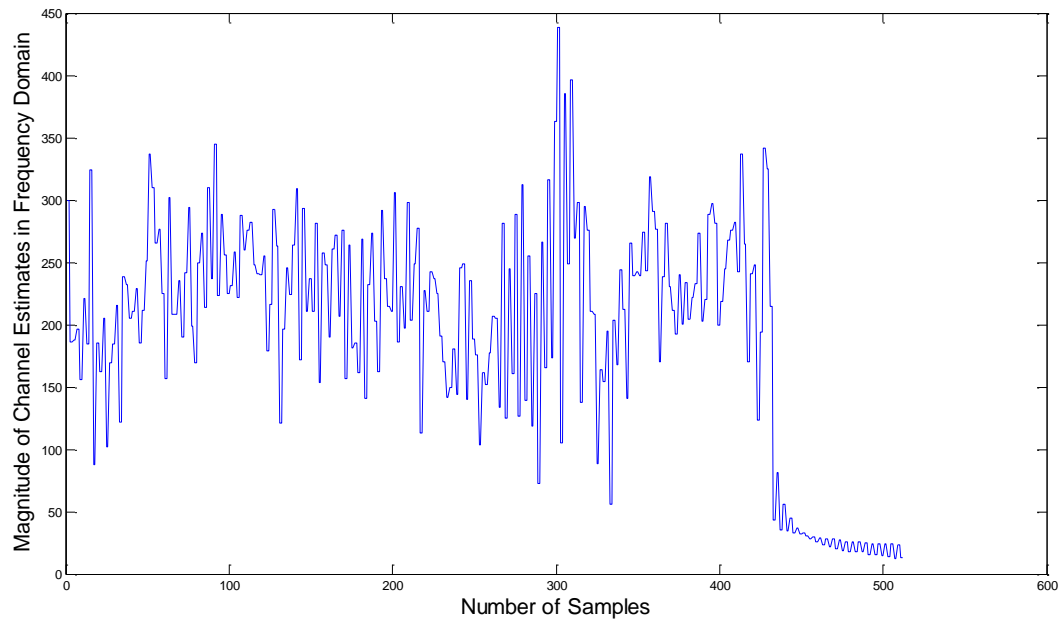

FIGURE A.4: Channel Estimates for Relay 1 in the Time-domain

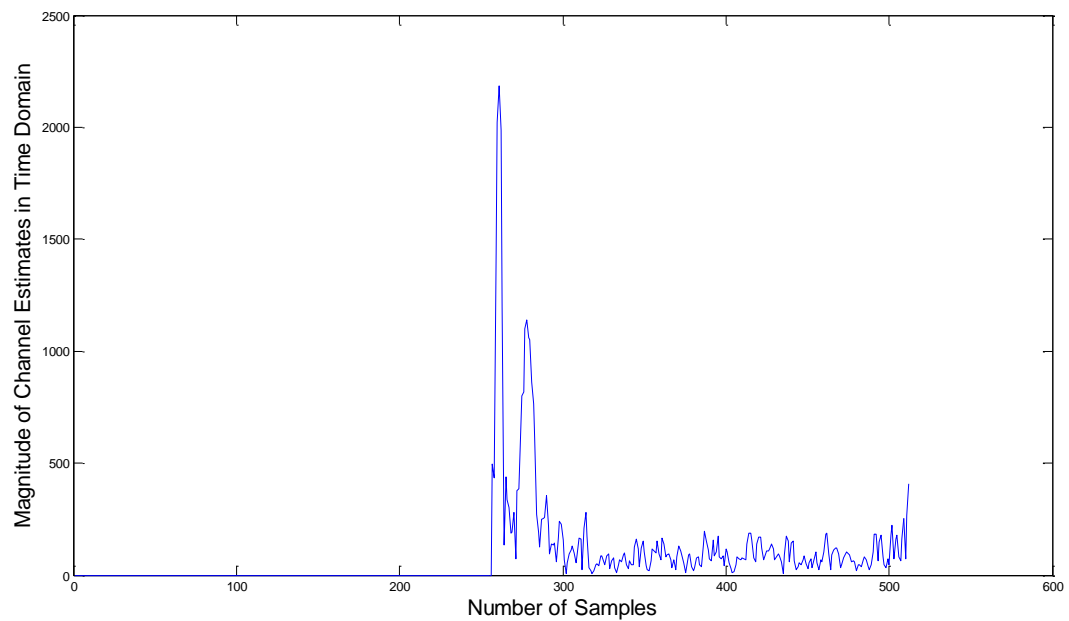

FIGURE A.5: Channel Estimates for Relay 0 in the Frequency-domain

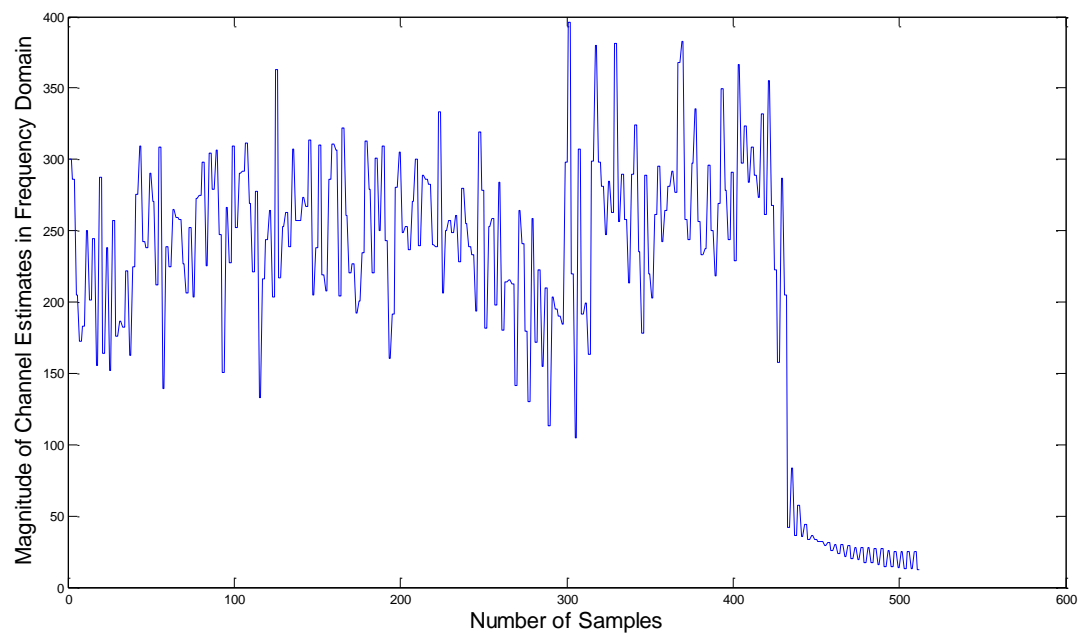

FIGURE A.6: Channel Estimates for Relay 1 in the Frequency-domain

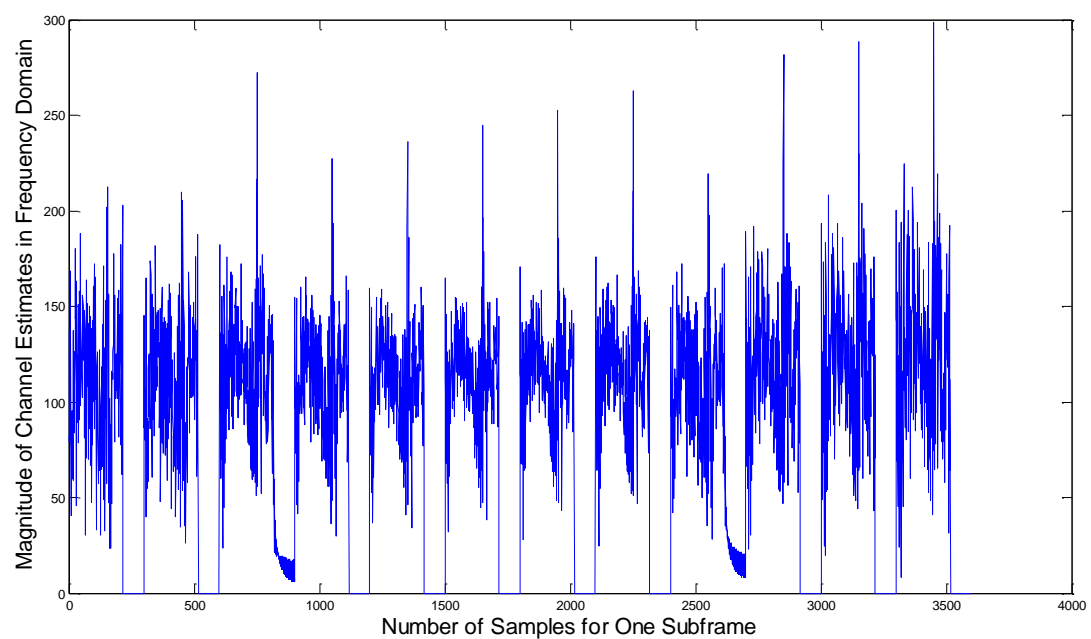

FIGURE A.7: Channel Estimates for Relay 0 in the Frequency-domain for One Subframe

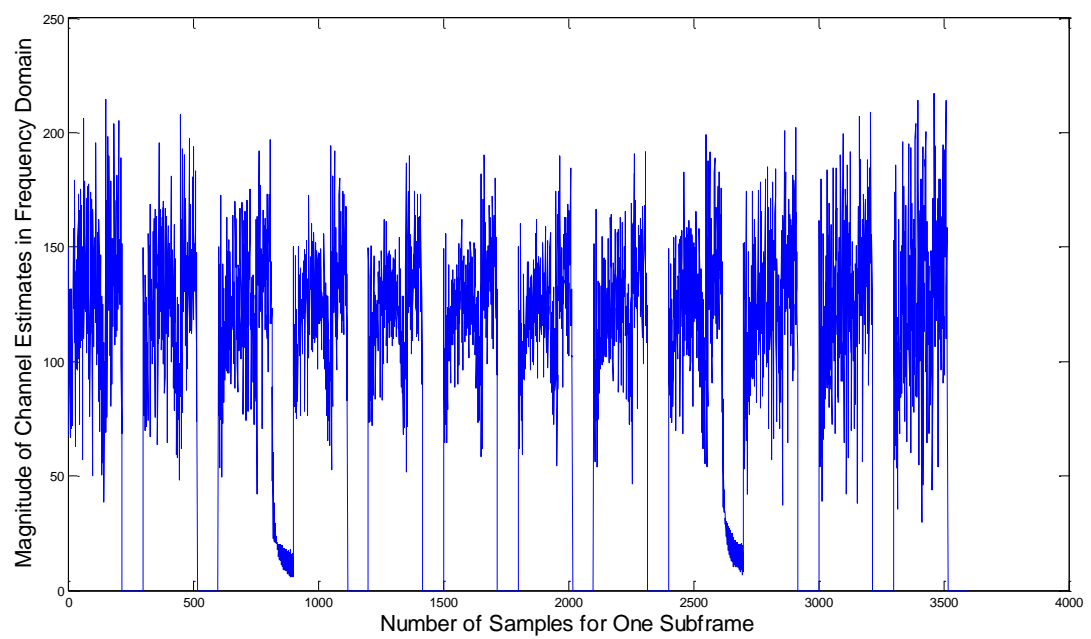

FIGURE A.8: Channel Estimates for Relay 1 in the Frequency-domain for One Subframe

# Bibliography

- [1] S. Parkvall, E. Dahlman, A. Furuskar, Y. Jading, M. Olsson, S. Wanstedt, and K. Zangi. Lte-advanced - evolving lte towards imt-advanced. *IEEE 68th Vehicular Technology Conference, 2008. VTC 2008-Fall.*, pages 1–5, September 2008.
- [2] T. Cover and A.E. Gamal. Capacity theorems for the relay channel. *IEEE Transactions on Information Theory*, vol. 25, no. 5: pp. 572–584, September 1979.
- [3] A. Nosratinia, T.E. Hunter, and A. Hedayat. Cooperative communication in wireless networks. *IEEE Communications Magazine*, vol. 42, no. 10: pp. 74–80, October 2004.
- [4] Pierre Lescuyer and Thierry Lucidarme. *Evolved Packet System*. John Wiley & Sons, 2008.
- [5] S. Weinstein and P. Ebert. Data transmission by frequency-division multiplexing using the discrete fourier transform. *IEEE Transactions on Communication Technology*, vol. 19, no. 5: pp. 628–634, October 1971.
- [6] Jr. Cimini, L. Analysis and simulation of a digital mobile channel using orthogonal frequency division multiplexing. *IEEE Transactions on Communications*, vol. 33, no. 7: pp. 665–675, July 1985.
- [7] 3GPP TS 36.212. Evolved universal terrestrial radio access: Multiplexing & channel coding. ver. 8.6.0, March 2009. URL <http://www.3gpp.org/ftp/specs/html-info/36212.htm>.
- [8] A. Doukas and G. Kalivas. Analysis and performance evaluation of a k-symbol pilot assisted channel estimator using linear interpolation for ofdm systems. *Wireless Communications and Networking Conference, 2007.WCNC 2007. IEEE*, pages pp. 1247–1252, March 2007.

- [9] M.S. Rana, M.M. and Islam and A.Z. Kouzani. Peak to average power ratio analysis for lte systems. *Communication Software and Networks, 2010. ICCSN '10.*, pages 516–520, February 2010.
- [10] K. Raghunath and A. Chockalingam. Sc-fdma versus ofdma: Sensitivity to large carrier frequency and timing offsets on the uplink. *Global Telecommunications Conference, 2009. GLOBECOM 2009. IEEE*, pages pp. 1–6, December 2009.
- [11] K. Loa, Chih-Chiang Wu, Shiann-Tsong Sheu, Yifei Yuan, M. Chion, D. Huo, and Ling Xu. Imt-advanced relay standards [wimax/lte update]. *IEEE Communications Magazine*, vol. 48, no. 8: 40–48, August 2010.
- [12] K. Doppler, C. Wijting, and K. Valkealahti. On the benefits of relays in a metropolitan area network. *Vehicular Technology Conference, 2008. VTC Spring 2008. IEEE*, vol. 48, no. 8: pp. 2301–2305, May 2008.
- [13] Lizhong Zheng and D.N.C. Tse. Diversity and multiplexing: A fundamental tradeoff in multiple-antenna channels. *IEEE Transactions on Information Theory*, vol. 49, no. 5: pp. 1073–1096, May 2003.
- [14] Y. Eisenberg and C. Logan. Cooperative communications for improved throughput, range and covertness. *Military Communications Conference, 2008. MILCOM 2008. IEEE*, pages 1–7, November 2008.
- [15] Yabo Li, Wei Zhang, and Xiang-Gen Xia. Distributive high-rate spacefrequency codes achieving full cooperative and multipath diversities for asynchronous cooperative communications. *IEEE Transactions on Vehicular Technology*, vol. 58, no. 1: pp. 207–217, January 2009.
- [16] Stefania Sesia, Issam Toufik, and Matthew Baker. *LTE - The UMTS Long Term Evolution*. John Wiley & Sons, 2009.
- [17] R. Vaze, V. Shashidhar, and B. Sundar Rajan. A high-rate generalized coded delay diversity scheme and its diversity-multiplexing tradeoff. *IEEE International Conference on Communications, 2005. ICC 2005.*, vol. 1: pp. 448–452, May 2005.
- [18] F. Sanchez, T. Zemen, G. Matz, F. Kaltenberger, and N. Czink. Cooperative space-time coded ofdm with timing errors and carrier frequency offsets. *IEEE ICC, Kyoto, Japan, 2011 (submitted)*, 2011.



- [19] Y. Jing and B. Hassibi. Distributed space-time codes in wireless relay networks. *Sensor Array and Multichannel Signal Processing Workshop Proceedings, 2004*, pages 249–253, July 2004.
- [20] D. Chu. Polyphase codes with good periodic correlation properties (corresp.). *IEEE Transactions on Information Theory*, vol. 18, no. 4: pp. 531–532, July 1972.
- [21] R. Frank, S. Zadoff, and R. Heimiller. Phase shift pulse codes with good periodic correlation properties (corresp.). *IRE Transactions on Information Theory*, vol. 8, no. 6: pp. 381–382, October 1962.
- [22] Kian Chung Beh, A. Doufexi, and S. Armour. Performance evaluation of hybrid arq schemes of 3gpp lte ofdma system. *IEEE 18th International Symposium on Personal, Indoor and Mobile Radio Communications, 2007. PIMRC 2007.*, pages 1–5, September 2007.
- [23] Insoo Hwang, Yungsoo Kim, and J. Kim. Analysis of a mimo relay system with harq. *IEEE 7th Workshop on Signal Processing Advances in Wireless Communications, 2006. SPAWC '06.*, pages 1–5, July 2006.
- [24] Wei Ni, Zhao Chen, and I.B. Collings. Hybrid arq based cooperative relaying in wireless dual-hop networks. *IEEE International Conference on Communications (ICC), 2010*, pages 1–6, May 2010.
- [25] S. O. Rice. Mathematical analysis of random noise. *Bell Syst. Tech. J.*, vol. 23, no. 6: pp. 282–332, July 1994.
- [26] Florian Kaltenberger, Gerhard Steinbock, Gerhard Humer, and Thomas Zemen. Mathematical analysis of random noise. *First European Conference on Antennas and Propagation, 2006. EuCAP 2006.*, pages 1–8, Nov 2006.
- [27] R. G. Gallager. *Information Theory and Reliable Communication*. John Wiley & Sons, 1968.
- [28] 3GPP TS 36.211. Evolved universal terrestrial radio access: Physical channel ‘& modulation. ver. 8.6.0, March 2009. URL <http://www.3gpp.org/ftp/specs/html-info/36211.htm>.
- [29] 3GPP TS 36.213. Evolved universal terrestrial radio access: Physical layer procedures. ver. 8.6.0, March 2009. URL <http://www.3gpp.org/ftp/specs/html-info/36213.htm>.