

To appear in *Annals of Operations Research*. Reprinted with the permission of the publisher.

An Oligopolistic Investment Model of the Finnish Electricity Market

Pierre-Olivier Pineau*

School of Public Administration, University of Victoria, Canada

Pauli Murto

Systems Analysis Laboratory, Helsinki University of Technology, Finland

Abstract

The investment problem faced by producers in deregulated electricity markets contains high uncertainties about the future. It can also be seen as a game, as only a small number of large players act in the market. A dynamic stochastic oligopoly model to describe the production and investment in such a situation is developed and applied to the Finnish electricity market. The demand growth rate is modeled as a stochastic variable. The strategies of the firms consist of investments and production levels for base and peak load periods. The firms have nuclear, hydro and thermal capacities, but are only allowed to invest in new thermal capacity. Using a so-called sample-path adapted open-loop information structure, the model contributes to the understanding of the dynamics of production, investment and market power in a medium time horizon. The solution method uses recent developments in variational inequality and mixed complementarity problem formulations.

Key words

Investment – Oligopoly – Uncertainty – Dynamic games – S-adapted equilibrium – Electricity markets

* Corresponding author: ppineau@uvic.ca

Introduction

Newly deregulated network industries, especially the electricity industry, have been the subject of many analysis during the last years (see for instance Gilbert and Kahn, 1996, Zaccour, 1998). Numerous papers also deal with competitive aspects (Bolle, 1992, Green and Newbery, 1992, von der Fehr and Harbord, 1993, and Green, 1997) and have greatly improved our understanding of firms' behavior in the new organizational framework. They have largely achieved their objective, which is to assess the possible market power of players and its impact on consumer prices. However, this literature focuses on static situations, leaving away investment decisions and therefore competition in the long run. Given a certain concern about long term adequate electricity supply, now that investment decisions are no more dictated by a central coordinator but are the result of a usual profitability analysis, dynamic competitive models are definitely needed (e.g. Smeers, 1997). Up to now, very few dynamic models have been proposed. In the realm of two-stage models, von der Fehr and Harbord (1995, 1997) assumed that the utilities choose investment in the first stage and price competition takes place in the second one. They isolate different effects in oligopolistic market affecting investments in capacity. These effects are twofold. First, they tend to induce under-investment to improve the players' market power. Second, they direct investment in specialized technologies having a marginal cost that affects spot prices to the players' advantage. These results are of great interest but do not give much insight on investment dynamics for multi-period settings. The case of investment in multi-technologies is further analyzed in a long-term perspective in Andersson and Håså (1997) but in a *perfect competition* setting¹.

Regarding investments, exogenous stochastic factors, such as the electricity demand growth, have a considerable importance. Unstable market growth creates risk, and this unavoidably influences investment decisions. In the electricity industry, where capacity costs are high, incorporating this element is therefore important.

This paper suggests a model that takes into account to a large extent the characteristics briefly discussed above. We consider a multi market segments oligopolistic dynamic model taking into account electricity demand growth as an exogenous stochastic element. Although one may think that the very purpose of deregulation is to converge to perfect competition, one can still argue that in many countries the game still involves very few competitors enjoying a certain market power. Further, given what has been said above, the dynamic aspect and the link with demand growth seem to be reasonable features of a model. We also assume that a utility can use different production technologies to satisfy demand. The model is written in terms of the Finnish industry.

The literature dealing with dynamic imperfect competition is considerable. In the energy area, Salant (1982) was probably the first to develop a dynamic game model of the oil market and many others followed (see for instance, Mathiesen et al., 1987, Haurie et al., 1988, and De Wolfe and Smeers, 1997, for models of the European gas market, or Hobbs and Kelly, 1992, and Younes and Ilic, 1998, for studies of transmissions prices and constraints in electricity). The modeling effort was accompanied by algorithmic developments for the computation of imperfect

¹ See also MARKAL models that have been developed to analyze long term trends in production, investments and other variables (e.g. environmental ones) in this kind of setting. Kanudia and Loulou (1998) is a recent application with more references to this type of models.

competition equilibria of games played on networks (see for example Murphy et al., 1982, Harker, 1984, Dafermos and Nagurney, 1987, Nagurney, 1988).

This paper naturally belongs to these literature streams. It adds to other contributions dealing with competition between newly deregulated electric utilities in three respects. First, the suggested model is dynamic which is not very usual in this literature. Second, it takes explicitly into account the interaction between electricity production, investment and demand growth. Third, to the best of our knowledge, it is the first attempt to study the Finnish market using dynamic game theory. Further, while dynamic game theory is seen as a powerful analytical tool, lack of empirical applications has limited its appeal to decision-makers. Hopefully, this application will clearly show that dynamic game models can be useful to them.

The rest of the paper is organized as follows: section 1 describes the Finnish electricity market, section 2 introduces the model, section 3 specifies the parameters and data used, section 4 discusses the results obtained, and section 5 concludes.

1 The Finnish electricity market

1.1 Deregulation of the Finnish electricity market

Finland does not have any significant natural energy resources. As a consequence, many generation technologies have been developed. The resulting energy supply sector is thus one of the most diversified in the world. Benefits of this situation are first that different characteristics of each technology are exploited, and second that dependence on a single supply origin is avoided. Table 1 shows the share of each energy source in the Finnish electricity supply industry. At the moment, however, prospects for increasing the use of some of these technologies (nuclear and hydro) are limited, due to socio-political considerations and the restricted availability of sites.

Table 1 Electricity supply by energy source in 1996 (Finergy and sener, 1997)

Energy source	Share of electricity supply (%)
Nuclear	27
Coal	21
Hydroelectric	17
Natural gas	10
Peat	8
Oil	2
Other	10
Imports	5

This diversity in production is probably a part of the explanation of the high number of firms that have always been involved in electricity generation (more than 100 according to Finergy and Sener, 1997). However, domination of larger producers, long-term contracts and restricted access to the transmission network prevented the electricity market to be really competitive. Conversely to most countries where the electricity industry structure was under governmental control, lack of

competition in the Finnish market was not due to governmental implication. Indeed, laws and governmental policies in Finland have enforced neither vertical nor horizontal integration, so that no monopolies were existing, except in the distribution sector². The *Electricity Market Act* (EMA) endorsed in 1995 by the Finnish parliament was then less a major change in the industry structure than a transfer of responsibilities, mainly at the transmission level.

If no real break down of the industry structure had to be done in Finland, what was the substance of the EMA? As reported in IEA (1994), key features were the opening of transmission and distribution networks and separation of book keeping for firms involved at the same time in production, transmission and distribution. Opening of the transmission network was done in 1997 with the creation of Fingrid, a single network operator and owner of most of the high voltage transmission network. The opening of the distribution network was completed in 1998, with retail competition.

In short, although the EMA aimed at more competition within the Finnish market and better integration with other Nordic countries, "deregulation" consisted only in a reform in the transmission sector and a few changes in the law at the distribution level. No major modifications in the generation level were performed, nor in the organization of trade, as we will see in the following subsections. Pineau and Hämäläinen (2000) describe in more detail the transformation of the Finnish electricity sector.

1.2 Generation and consumption levels

Electricity consumption in Finland in 1996 amounted to approximately 70 TWh (Nordel, 1998). Producers were the state-owned company Fortum³, industries and municipally owned energy firms. As it is still the case today, producers of the latter two categories did it mainly for their own usage, while Fortum supplied approximately 30% of the Finnish electricity consumption. The large number of electricity producers in Finland is also linked to the fact that lots of municipalities and industries produce their own power. It can be said that due to their small size, these companies constitute a competitive *fringe*. A large number of industrial firms have grouped their production under a common structure, *Pohjolan Voima* (PVO), supplying 20% of total consumption. With the development of electricity markets, PVO might be interested in selling its electricity in a more profit-oriented way. Its production would then not only be directed to its industrial owners, but to all market segments.

Consumption of electricity can be split in time between base and peak load periods. In approximately 80% of the time, the electricity consumption level requires a capacity that can be said to be the *base load* capacity. For the other 20% of the time, characterized by high demand, a higher *peak load* capacity is needed⁴.

² Even transmission was not a monopoly in Finland. A really surprising and unique feature of the previous Finnish electricity market was the presence of *two* concurrent national grids (see for example Ministry of Trade and Industry, 1997, page 53).

³ In 1996, the electricity business of Fortum was conducted by the firm IVO. In 1998 IVO merged with the state oil and gas company Neste under the name «Fortum».

⁴ See for example Confederation of Finnish Industry and Employers (1998).

1.3 Trades in the Finnish electricity market

Three types of trade can be distinguished in Finland. They are bilateral trades, spot market trades and trades in private pools.

Most of electricity transactions are still made in private bilateral contracts between sellers and buyers, usually producers and consumers (some energy brokers can also buy and resell electricity). For balance settlements, power exchanges can be made in private pools, based on least cost dispatch. These private pools only represent a marginal part of trading, since they are only used to avoid non-necessary start-up costs or expensive production caused by short and unexpected high levels of demand. Bilateral contracts are still the most common support of exchanges, even if the length of these contracts tends to decrease (IVO, 1997).

With the 1995 EMA, an independent electricity spot market was created (EL-EX). Contrasting with the well-known English case, this spot market is not mandatory, so that traditional bilateral contracts can be done independently. Volume of transactions remains low in this spot market, with a maximum of 15% of daily consumption on certain peak days⁵. However, the importance of the spot market is continuously increasing and spot price is now widely used as the reference price. Price formation in the spot market is thus crucial to the whole industry. In 1998, the Finnish spot market joined the Nordic spot market, Nord Pool. Although related, electricity prices in the Nord Pool area are different in the three main participating countries (Norway, Sweden and Finland), because of transmission constraints. Each country has one or many price zones. Finland represents one price zone, and we concentrate our analysis on that one.

1.4 Price formation in the Finnish zone

The spot market functions in a simple way. Each seller gives the quantity of electricity he is willing to sell at a certain price and time. Buyers also inform the spot market operator of their needs. The deal is made whenever supply and demand conditions meet.

As in any spot market, if supply is abundant, prices will tend to decrease, and if supply is scarce, prices will rise. Demand levels have also a major influence on price. Supply becomes relatively abundant in base load periods by low levels of demand. Conversely, in peak load periods, supply is more limited as demand approaches the maximal capacity available at that time. Prices will therefore be at a higher level.

Suppliers are free to offer whatever quantity they want in the spot market. It can therefore be assumed that some strategic behavior could take place on their side, as long as they represent a large share of the supply, big enough to influence the market price. In the Finnish market, this seems to be the case for the main producers, Fortum and PVO, as discussed previously.

2 A dynamic-stochastic model of electricity market

2.1 The scope of the model

In this section, we formulate a numerical model to characterize the competition between electricity producers in a deregulated electricity market. The purpose is to study how the

⁵ See the Nordel web site for some data on consumption and the volume of trade in the spot market (www.nordel.org).

electricity prices, production levels, and production capacities unfold in the absence of regulation. The main assumption is that the firms' behavior is fully determined by profit maximization. The model is defined for the Finnish electricity market, but the requirements that led us to this specific formulation are general and could apply to many other countries as well.

In the electricity market that evolves in time, there are two types of decisions the firms have to make. In the short term, they have to decide their production patterns in order to maximize the profit with given capacities. We assume that firms use output quantity as their decision variable⁶. On the other hand, they have to decide how much to invest in new production capacity in order to maximize the profits in the long run. These investment decisions have to be made under high uncertainties concerning the future. Also, the firms acknowledge that the optimal investment level is conditional on the investments of the other firms.

Before formally stating the model we discuss informally its most crucial features, namely the information structure adopted, and the way uncertainty is incorporated in the model.

2.2 The information structure: S-adapted

We use discrete time periods to model the dynamics of the market. In a multi-period game model, the information structure used is important when assessing the soundness of the strategies. Usually, three different cases are distinguished in the literature, namely open-loop, feedback, and closed-loop information structures (see Basar and Olsder, 1982, for example). In the open-loop structure the strategies are only functions of time and initial state. In the feedback structure the players use Markovian strategies, which are functions of the current state of the system. In the closed-loop structure the strategies are based on all available past information on the state of the system and actions of the players. The closed-loop and feedback information structures are desirable in the sense that the actions defined by the strategies are adapted to other players' decisions during the time horizon.

The problem with closed-loop and feedback information structures is that they make the solving of the model generally difficult, because the strategy spaces are much larger than in the open-loop case. Closed-loop solutions can only be found in a restricted class of special cases, for instance in linear quadratic cases. A feedback information structure would call for the use of backward induction. However, the scope of the model considered in this paper (many periods, many different stochastic events and continuous investments and production decisions) prevents a straightforward implementation of this approach. Intermediate computation of Nash equilibria, needed in order to calculate each player's profit within each period, would also add an extra layer of technical difficulty.

On the other hand, closed-loop and feedback information structures are also subject to criticism. It is not necessarily very realistic to assume that when making their decisions, the firms fully utilize past information about the state variables, and also acknowledge that other firms do and will do so in the future. Expecting such refined behavior from firms might be spurious.

⁶ This Cournot assumption is the most popular one in the literature, see e.g. Salant (1982), Haurie et al. (1988), Andersson and Bergman (1995), Borenstein et al. (1999). Different approaches are, e.g., Hobbs (1986), who assumed Bertrand behaviour, and Bolle (1992), Green and Newbery (1992) and Green (1997), who studied the English pool using supply function equilibrium (see Klemperer and Meyer, 1989, for the theory).

Haurie et al. (1990) introduce in their paper an information structure called S-adapted, which suits well to the situation we are considering. This structure is similar to the open-loop one, except that the strategies of the players adapt to the sample path of the stochastic variable (therefore the name S-adapted, for sample). In our case, the stochastic variable is the demand growth (see the next section for more discussion on this). Their paper shows that the Nash equilibrium corresponding to this information structure can be calculated using stochastic equilibrium programming techniques. This means that possible realizations of the stochastic variable form a tree-type structure, but instead of using the optimization criterion as in stochastic programming, the Nash-Cournot equilibrium computation is performed over the whole sample space so that the players maximize their expected profits. As a result, the computation of the equilibrium is in principle not different from computing a static Nash-Cournot equilibrium.

The Nash equilibrium corresponding to the S-adapted information structure can be said to lie halfway between the closed-loop and open-loop equilibria. It bears some of the main properties of the normal open-loop solution. For instance, the solution is not subgame perfect⁷. Also, the equilibrium corresponds to the situation where the players have to commit themselves to certain action patterns at the beginning of the game. Nevertheless, in the S-adapted case this commitment is conditional on the stochastic variable and the actions are therefore not predetermined as in the open-loop solution. The interested reader is referred to Haurie et al. (1990) for a full discussion of S-adapted information structure. In Haurie et al. (1988) another application is developed.

We believe that the S-adapted open-loop solution offers valuable insight on the dynamic market behavior under uncertainty. It is relevant in the electricity field, where it can be argued that the firms usually stick to certain investment plans for some time. It is also more likely that the firms rather adapt their investment decisions to the external shocks than to the investment decisions of the other firms, at least in a medium time scale such as the one considered here. In that sense also, the chosen solution concept can be a useful representation of the producers' actions.

Finally, with no other models available to analyze investment dynamics under uncertainty in an oligopoly context, this characterization gives a first contribution to the analysis. It could also serve as a benchmark case for future analysis using different information structures.

2.3 Stochastic electricity demand growth

Energy consumption growth, as well as economic growth, is forecasted by many organizations due to its importance in the world economy. However, forecasts are never completely reliable

⁷ Closed-loop and feedback solutions are subgame perfect because the associated strategies are Nash equilibria at each stage of the game, even if there has been a deviation from the equilibrium strategy in an earlier subgame. Open-loop solution cannot have this property, because strategies are not defined separately for states that have been reached by deviations from the equilibrium. However, to prevent a typical misunderstanding on the properties of different equilibrium concepts, it should be emphasized that open-loop Nash equilibrium, as well as the S-adapted one, are time consistent (Basar and Olsder, 1995, use the term «weak time consistency», see pages 256-259). This means that the players do not have an incentive to deviate during the game when moving along equilibrium trajectories. Would the equilibrium strategies be re-computed in a further stage, they would remain the same.

and uncertainty should be included in any analysis using them. Due to the importance of demand growth in electricity production and investment, we model here two growth possibilities for each period. According to forecast of IEA (1997), electricity consumption level in Finland should grow by 3.8% in 2000, followed by a yearly growth of 2.4% until 2005 and finally 1.9% to the end of 2010. To reflect these various growth levels, we use a stochastic growth with two discrete levels (0 and 3%) in each period.

Event trees are often used to model stochastic events as in Haurie et al. (1988) and Kanudia and Loulou (1998). Figure 3.1 shows a simple tree of two periods. The first period is represented by one node, where two growth levels, high (H) and low (L), can occur. The demand parameter A_j^t is affected by the realization of a particular growth level.

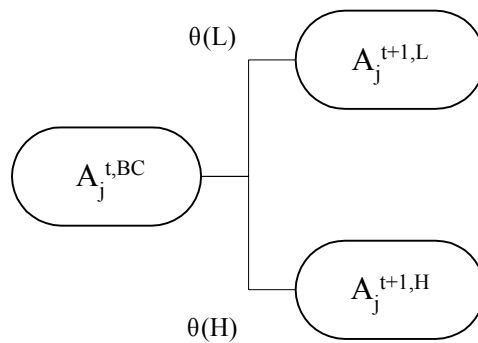

Figure 1 Simple event tree for demand scenarios (BC = *base case*, L = *low*, H = *high*)

When the model has many periods, these nodes form an event tree, which branches at each period. This results in a growing number of nodes per period. A certain path through the tree corresponds to a scenario of events. The strategies of the players at each node take into account all possible future nodes and the probabilities at which they will be faced. The solution of the model gives the actions of the players under all possible scenarios. It takes into account the fact that the players do not know during the game which sample path would be realized.

2.4 The formal definition of the model

The Finnish electric industry is represented by many strategic players and a competitive fringe in production. At each period, players choose their investment and quantities to be produced by each production unit and at each of the two demand levels.

The time horizon is 10 years long. It is divided into five two-year periods. This setting is explained by the following reasons. First, the production strategies need a certain commitment from players, as they cannot constantly change their production planning. The time period of two years is approximately the time implementation of new thermal production units. Second, the horizon considered is long enough to let investment take place in new thermal capacity. In other words, a shorter time horizon may not involve positive investment due to the fact that actual

capacities are sufficient to fulfill the demand. In this framework, each player seeks to maximize his discounted stream of profits. For simplicity, we assume that all players adopt the same market discount rate.

The notation is defined as follows:

$i = 1, \dots, m$	player (generator)
$l = 1, 2$	production type ($l = 1$ is hydro/nuclear; $l = 2$ is thermal)
$j = 1, 2$	load period ($j = 1$ is base load; $j = 2$, peak load)
h_j	number of hours in a year for load period j ($h_1 = 7008$, $h_2 = 1752$)
n	number of years in a period ($n = 2$)
$\tau = 1, \dots, 5$	period
β	discount factor (per period)
s^τ	demand growth level at τ (random variable)
$\bar{s}^\tau = \{s^1, \dots, s^\tau\}$	history of growth level development from 1 to τ
$\theta(\bar{s}^\tau)$	probability of \bar{s}^τ
$K_{il}^\tau(\bar{s}^{\tau-1})$	capacity of player i in units of type l at period τ (MW)
$I_{il}^\tau(\bar{s}^\tau)$	capacity addition of player i in type l at period τ and \bar{s}^τ (MW)
$\Gamma_l(I_{il}^\tau)$	cost of investment in type l capacity (Euro / MW)
$V_{il}(K_{il}^5)$	salvage value of the capacity of type l for player i at period 5
$q_{ij}^\tau(\bar{s}^\tau)$	yearly production of i in units of type l at load period j at τ and \bar{s}^τ (MWh)
$q_{il}^\tau(\bar{s}^\tau) = \sum_j q_{ij}^\tau(\bar{s}^\tau)$	total quantity produce by generator i in type l at period τ and \bar{s}^τ (MWh)
$Q_j^\tau(\bar{s}^\tau) = \sum_i \sum_l q_{ij}^\tau(\bar{s}^\tau)$	total quantity for load period j at period τ (MWh)
$C_{ij}(q_{ij}^\tau)$	total production cost function of generator i in type l at load period j (Euro)
$P_j^\tau(Q_j^\tau, s^\tau)$	inverse demand function at load period j at period τ (Euro / MWh)

As stated above, each player maximizes his expected profit π_i . The argument \bar{s}^τ is omitted when no confusion is possible.

$$(1) \quad \text{Max } \pi_i = \sum_{\tau=1}^5 \left\{ \beta^\tau \sum_{\bar{s}^\tau} \left\{ \theta(\bar{s}^\tau) \sum_{l=1}^2 \left[\sum_{j=1}^2 n \cdot [q_{ij}^\tau(\bar{s}^\tau) \cdot P_j^\tau(Q_j^\tau, s^\tau) - C_{ij}(q_{ij}^\tau)] - \Gamma_l(I_{il}^\tau) \right] \right\} \right\} + \beta^5 \sum_{\bar{s}^5} \left\{ \theta(\bar{s}^5) \sum_{l=1}^2 [V_{il}(K_{il}^5)] \right\}$$

subject to:

$$(2) \text{ Capacity investment} \quad K_{il}^{\tau+1}(\bar{s}^\tau) = K_{il}^\tau(\bar{s}^{\tau-1}) + I_{il}^\tau(\bar{s}^\tau) \quad (\text{state equation})$$

$$(3) \text{ Production capacity} \quad 0 \leq q_{ij}^\tau(\bar{s}^\tau) \leq K_{il}^\tau(\bar{s}^{\tau-1}) \cdot h_j$$

(4) Non negativity

$$q_{il}^\tau(\bar{s}^\tau), I_{il}^\tau(\bar{s}^\tau) \geq 0$$

The objective function (1) is simply the discounted sum over all five periods of expected revenues minus total production and investment costs, plus the salvage value. We do not consider transmission price for two reasons. The first is that in Finland, transmission prices are uniform and negligible compared to production cost. The second is that in Finland, transmission is hardly a limitation for trading nor could become a strategic advantage for one generator. This is so because the policy of the transmission network operator is to maintain over capacity in all lines. In such a context, ignoring transmission pricing and constraints is not a major simplification.

2.5 Solving the model

Let us define for each player the vector $y_i = \{q_{ij}^\tau(\bar{s}^\tau), I_{il}^\tau(\bar{s}^\tau)\}$, which contains all decision variables (for all i, j, l, τ and \bar{s}^τ). Let Ω_i be the set of all admissible actions for player i and $\Omega = \prod_{i=1, \dots, m} \Omega_i$ the set of admissible actions for all players.

Definition: $y^* = \{y_1^*, \dots, y_m^*\} \in \Omega$ is an open-loop S-adapted Nash-Cournot equilibrium if for $\forall y_i \in \Omega_i$ and $\forall i = 1, \dots, m$:

$$\pi_i(y^*) \geq \pi_i(y_1^*, \dots, y_{i-1}^*, y_i, y_{i+1}^*, \dots, y_m^*).$$

Proposition: If the cost functions $C_{ij}(\cdot)$ and $\Gamma_l(\cdot)$ are convex and continuously differentiable, and the revenue function $q_{ij}^\tau \cdot P_j^\tau(\cdot)$ is concave, then there exists at least one open-loop S-adapted Nash-Cournot equilibrium for the problem (1) - (4).

The proof of existence of the oligopolistic Nash-Cournot equilibrium is well established in many papers. See Murphy, Sherali and Soyster (1982) or even Friedman (1977). The open-loop information structure adopted here allows a static formulation of the problem. The many periods, market segments and technologies we introduced only add to the dimension of the problem, but do not change its nature. See also Haurie et al. (1988, 1990) for proofs in similar contexts.

A proof for uniqueness of the equilibrium would require strictly convex cost functions, a condition that is not fulfilled in the implementation. However, the computations converged to a similar unique solution in both of the solution approaches we used.

Equilibria in oligopolistic energy markets have been investigated from a computational point of view in many papers since Salant (1982), where one of the first multi-period oligopolistic energy models was developed. More specifically, Murphy, Sherali and Soyster (1982) developed a mathematical programming approach for determining oligopolistic market equilibrium, which was improved by Harker (1984) and Marcotte (1983) with the use of variational inequalities. Algorithms for variational problems were already available (see for example Pang and Chan, 1982), so that efficient tools could be used when the oligopolistic market equilibrium problem was reformulated with variational inequalities. A number of applications followed, especially in traffic assignment and network equilibrium. Harker and Pang (1990) give a survey of these

applications beside a more global overview of the theory and algorithms⁸. See also Nagurney (1993) for a general presentation of variational inequalities and their applications to network economics.

Generally, two main approaches for finding the equilibrium of such problems exist. We solved the problem using both of them. The first one is to solve directly the necessary conditions of the Nash equilibrium. Writing the first order optimality conditions simultaneously for all players results in a nonlinear complementary problem. A general purpose complementarity code like MILES (Rutherford, 1993) can then be used in solving this.

The second approach is less direct and uses an optimization-based algorithm. The Nash-Cournot game we are considering corresponds to the optimization problem 1 solved simultaneously for all players. If (1) is reformulated as a minimization problem, then it is possible to prove from the first order conditions that the optimal solution x^* of the game is the solution of the following variational inequality $VI(\nabla\Pi, X)$ ⁹

$$\nabla\Pi(x^*)^T \cdot (x-x^*) \geq 0, \quad \forall x \in X$$

where X is the compact and convex set of feasible solutions, defined by equations (2)-(4), for all players. The equilibrium values of the decisions variables for all the players are grouped in vector x^* . $\Pi(x^*)$ is the vector containing the objective functions for all players, in a minimization format. $\nabla\Pi(x^*)$ includes all the derivatives of $\Pi(x^*)$.

We then use the *nonlinear Jacobi* algorithm, also known as the diagonalization or relaxation algorithm. Harker (1984), among many others, uses this algorithm. It takes each player in turn and optimizes its profit with fixed values for other players' decision variables. Successive applications of these optimizations lead to the global equilibrium, if conditions for convergence are respected. Our model is a direct extension of Harker's model, which respects conditions of convergence stated by Pang and Chan (1982). Basically, what is needed for the convergence is the concavity of the profit function and that the initial vector x^0 is in a suitable neighborhood of x^* .

The GAMS codes of both solution approaches are available from the authors on request.

3 Set of data

3.1 Players

For our base case drawn from the main features of the Finnish electricity market, we consider two players roughly representing Fortum and PVO, plus a third one, standing for the rest of the supply side. This third player is studied under different behavioral assumptions (strategic and competitive). When considered as a strategic player, his behavior would correspond to the choice of a "PVO-style" strategy from these many producers. It would mean a merger between them, resulting in one single strategic entity. When considered as a competitive fringe, this third player

⁸ Books like Bertsekas and Tsitsiklis (1989) and Nagurney (1988) also give the necessary background to implement variational inequality algorithms in oligopolistic game settings.

⁹ See Nagurney (1988) page 5 or Kinderlehrer and Stampaccia (1980) page 1-2 for a proof of this.

has no market power. Table 2 presents production and capacity data in the Finnish market for 1996.

Table 2 Capacity in Finland, 1996 (IVO, 1997; PVO, 1997, and Nordel 1998)

		Total capacity	Total production
		MW	TWh
Fortum	Nuclear and hydro	2500	21.0
	Thermal	3000	
PVO	Nuclear and hydro	1200	15.3
	Thermal	1800	
Others	Nuclear and hydro	1590	33.7
	Thermal	5710	
		15800	70

3.2 Demand

Consumers in each market segment are represented by the following linear inverse demand function

$$(5) \quad P_j^\tau(Q_j^\tau, s^\tau) = A_j^\tau(s^\tau) - B_j \cdot Q_j^\tau(\bar{s}^\tau)$$

where $A_j^\tau(s^\tau)$ and B_j are parameters scaling the level of demand. These parameters depend on the load period j and for the first one, on the level of growth. They were set using the price elasticity of demand η_j for load period j at time $\tau = 0$ and the observed price of electricity¹⁰ in the two load periods. We discuss how elasticity is set in section 4.4. Figure 2 shows these demand curves for the base and peak load periods¹¹.

¹⁰ Prices were approximated at 100 and 200 Finnish Marks per MWh (16.82 and 33.64 Euro/MWh), for respectively base and peak load periods, with loads of 7000 and 11000 MW (based on Nordel, 1998).

¹¹ It should be noticed that as we make the assumption that base and peak load demand are constant during their respective number of hours (7008 and 1752), demand in each period can equivalently be expressed in MW or MWh.

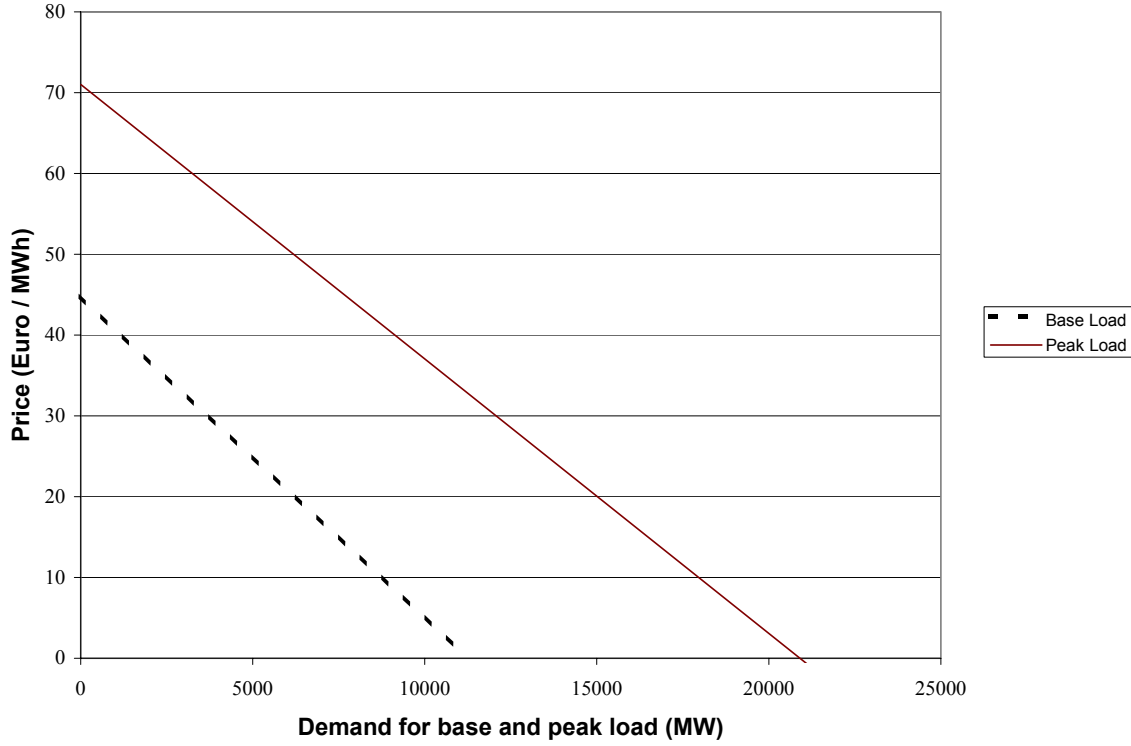

Figure 2 Peak and base load demand at $\tau = 1$

3.3 Cost structure

Production cost functions are different for hydro and nuclear units on one hand ($l = 1$) and thermal units on the other hand ($l = 2$). Their functional forms are presented in equations (6) and (7) respectively. They are similar to those used in Andersson and Bergman (1995).

$$(6) \quad C_{i1j}(q_{i1j}^\tau) = g_1 \cdot q_{i1j}^\tau$$

$$(7) \quad C_{i2j}(q_{i2j}^\tau) = g_2 \cdot q_{i2j}^\tau + (h_j \cdot K_{i2}^\tau \cdot b_2 / (\phi + 1)) (q_{i2j}^\tau / (h_j \cdot K_{i2}^\tau))^{\phi + 1}$$

In the production cost function (6) for hydro and thermal units, g_1 is taken the same for all players. For simplicity, hydropower is assumed to have the same marginal cost as nuclear power. In (7), the parameter ϕ must be greater than one. This cost function allows a rapid increase of production cost as quantity grows and is produced by more expensive thermal units. A capacity investment both increases the maximum output and shifts the cost curve downwards. Thus, investments increase the thermal capacity uniformly, i.e. add units with low and high marginal production cost. The cheapest marginal production cost is g_2 and $(g_2 + b_2)$ is the highest. This can be seen more easily from the marginal cost function:

$$(8) \quad c_{i2j}(q_{i2j}^\tau) = g_2 + b_2 (q_{i2j}^\tau / (h_j \cdot K_{i2}^\tau))^\phi$$

It should be noted that both of the cost functions (6) and (7) have the property that given some capacities for each firm, the cost of producing a given total quantity when the firms coordinate their production in order to minimize the total production cost is the same as if the same total capacity is given to one firm, which produces the quantity according to its individual cost function¹². This makes it possible to interpret the sum of the firms' capacities as the total industry capacity, and the industry cost function as the minimum total cost of producing some output using the firms' capacities. Each investment has the same effect on the industry cost function, no matter which firm undertakes it. This is particularly important in section 4.2, where we will compare the results with different numbers of players and also establish the competitive benchmark solution.

Table 3 shows the marginal production costs of some technologies used in different *blocks* of the load duration curve. These values are used to determine the parameters g_1 , g_2 , and b_2 . For ϕ we have chosen the value $\phi=2$.

Table 3 Marginal production cost of different technologies (Confederation of Finnish Industry and Employers/Finland Promotion Board, 1998)

Technology	Marginal production cost (Euro / MWh)
Nuclear	4.20
Thermal (lowest)	15.14
Thermal (highest)	40.36

3.4 Investment cost

Investment cost function $\Gamma_l(I_{il}^\tau)$ for technology l is assumed linear and increasing:

$$(9) \quad \Gamma_l(I_{il}^\tau) = a_l \cdot I_{il}^\tau$$

Investments in nuclear and hydro production units are restricted due to limited availability of sites and strict licensing requirements, at least in the short term¹³. Therefore we do not allow investments in these technologies in the model. In contrast, thermal technologies are readily

¹² This can be seen by defining the cost as a function of both output and capacity. Let $C(q,K)$ be the cost of producing output q with capacity K . Both of our cost functions (6) and (7) have the properties 1) $C(w \cdot q, w \cdot K) = w \cdot C(q,K)$ and 2) $C'(w \cdot q, w \cdot K) = C'(q,K)$, where w is an arbitrary positive constant and $C'(\cdot, \cdot)$ is the derivative of the cost function with respect to q . This implies that if all firms have the same cost function, the minimum cost of producing q with total capacity K is $C(q,K)$, no matter how the capacity is split between the firms. The minimum total cost is achieved when the ratio of a firm's output to the total output is the same as the ratio of its capacity to the total capacity.

¹³ Finland does not have any free hydro sites to use, but the possibility to build new nuclear power capacity has actually been an important topic of discussion lately. The parliament decided in 2002 to allow one new unit to be built.

available, within a short implementation time. Investment costs used in the analysis for the base case and low investment cost case are 340 000 and 170 000 Euro / MW respectively¹⁴.

Physical depreciation is not included in the model (existing capacity remains the same through time). Generation units have indeed a very long life expectancy, and with adequate maintenance, their capacity is not really altered with time. They even hardly close completely. For example, in 1997 not a single MW of capacity was shut down in Finland and only 0.4% of the total Nordic capacity was decommissioned (Nordel, 1998).

However, the financial value of capacity is decreasing each year. As technology evolves and gains in efficiency, the value of a power plant diminishes each year. A 2% depreciation rate is used to reflect this loss in competitiveness of older units. A sensitivity analysis is made on this value to assess how reactive to depreciation the results are. Investments made during the horizon considered will then have a salvage value equal to their initial purchased cost, minus 2% of depreciation each year.

3.5 Time length

We consider five decision periods, lasting two years each. A discount factor $\beta = 0,95$ is used. This 10 years horizon is interesting because it gives a mid-term perspective on production and investment, when capacity changes are likely to be due to investments in relatively small thermal plants.

4 Results and sensitivity analysis

4.1 Market structure scenarios

From the 1996 situation presented in table 2 (not structurally different from the 1999 situation), we develop three different assumptions on the Finnish generation capacity. Each of these assumptions is a possible scenario and presents some highlights on how merger and concentration could affect the market price. In addition to these scenarios, we also consider the benchmark case, where the supply side of the market is assumed to be perfectly competitive. That case is presented in the next section.

- **Competitive fringe (A).** In this first scenario, we stay close to the current situation (presented in table 2) by assuming strategic behavior for the two large players (Fortum and PVO) and competitive behavior for the third one. Capacities are as in table 2, but the fringe is assumed not to invest and only reacts to the production choices of the two other players.
- **Strategic with acquisitions (B).** Here it is assumed that some of the fringe capacity is divided between Fortum and PVO, and also that all the nuclear and hydro capacity becomes

¹⁴ Thermal investment cost for the base case is taken from the Table 14 in the *Financial - Investor-Owned Electric Utilities* section of the Energy Information Administration web site (www.eia.doe.gov). For comparison, some variable and fixed costs in electricity production for different technologies are presented in Andersson and Håså (1997).

under their control¹⁵. The rest of the fringe becomes a third strategic player and gets one third of the thermal capacity. The merger and acquisition pressures of the market justify this scenario. This scenario will be considered as the "BASE CASE".

- **Strategic no acquisition (C).** Simply as a benchmark, we assume in this last scenario that the original fringe capacity merges together and constitutes a third strategic firm. This assumption, however, gives it a dominant capacity, that would probably not be allowed by the two other players, who might acquire some of the fringe capacity (as in the previous scenario).

Table 4 shows the initial capacities of the three scenarios considered.

Table 4 Scenario description - Capacities (MW)

Scenario		Players' capacity		
		Fortum (strategic)	PVO (strategic)	Other
A – Competitive Fringe	<i>Nuc./Hydro</i>	2500	1200	1590
	<i>Thermal</i>	3000	1800	5710
B – Strategic with acquisitions	<i>Nuc./Hydro</i>	3250	1950	-
	<i>Thermal</i>	4000	2800	3710
C – Strategic no acquisition	<i>Nuc./Hydro</i>	2500	1200	1590
	<i>Thermal</i>	3000	1800	5710

With the tree structure of the model, two random choices at each node and five periods, the results consist of 16 equally likely different paths through the five periods. Presenting the data for these 16 possible paths would be not only a confusing task, but also unnecessary because many of these paths are almost similar. Thus, we present only three important possibilities:

- **No growth case.** In this extreme case no growth occurs in any period.
- **Average growth case.** Here 0 and 3% growth alternate during the five periods.
- **High growth case.** The maximum demand growth of 3% is realized each year.

The resulting prices in each of the five time periods, for the base and peak load market segments are presented in figures 3 and 4. It can be mentioned that all the obtained results are of the same magnitude than the real prices observed in the market during peak and base load periods (see www.nordpool.com for the spot prices).

¹⁵ The size and risk of nuclear power plants explain by themselves the pressure to centralize ownership. In the case of hydro power plants, their successive position in rivers justifies concentrated management.

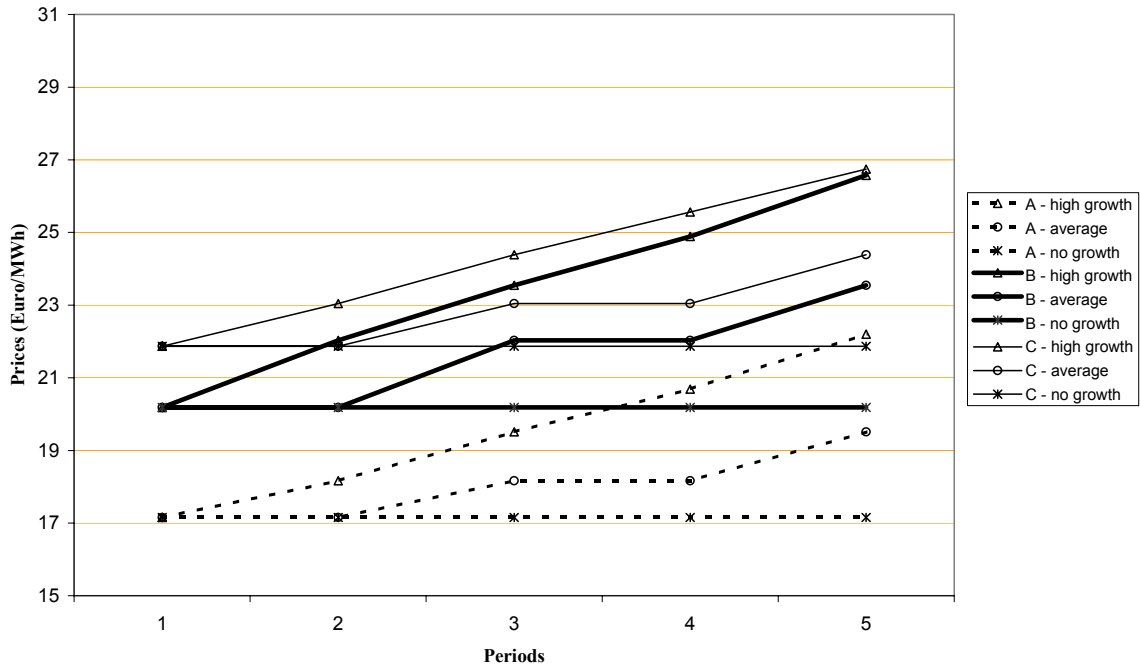

Figure 3 Base load prices in 3 demand growth paths - 3 company structure assumptions

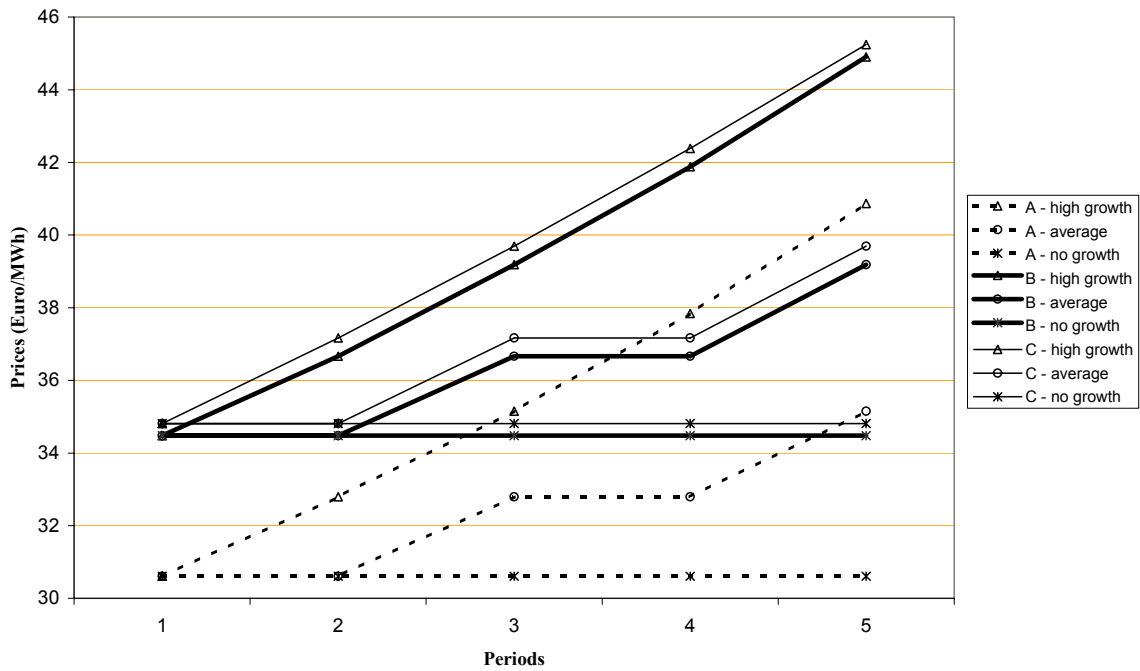

Figure 4 Peak load prices in 3 demand growth paths - 3 company structure assumptions

The first result easily seen from these figures is that the lowest prices are obtained in the competitive fringe scenario (A). This shows how important is the presence of small players,

acting as price takers, from the point of view of market performance. This feature is particularly prevalent in peak load periods, when the market power effects are stronger.

In all three cases, almost no investment takes place. High cost and limited horizon prevent investment to be profitable. These results of the model concur with the actual observation in the market. An interesting pattern observed in the outcome of the model is that as demand grows, the capacity becomes more and more binding in peak load periods, giving room for more market power of the players. Figure 4, compared to figure 3, shows that prices are rising more in the peak load period than in the base load one, because in base load the exceeding capacity prevents a stronger exercise of market power.

4.2 Number of players and competitive benchmark

Because of the uncertainty about the number of players in the future, we study here the impact of this point on the results of the model. Table 5 has the capacities, at period 1, used in the market analysis with different numbers of players. The total capacity is always 15,500 MW. The 3-players case we are considering here is the base case (B - Strategic with acquisition).

Table 5 Scenario description - Initial capacities (MW)

Scenario		Players' capacity				
		Player 1 (Fortum)	Player 2 (PVO)	Player 3	Player 4	Player 5
Monopoly	<i>Nuc./Hydro</i>	5000	-	-	-	-
	<i>Thermal</i>	10500	-	-	-	-
Duopoly	<i>Nuc./Hydro</i>	3295	1995	-	-	-
	<i>Thermal</i>	5855	4655	-	-	-
BASE CASE 3-players	<i>Nuc./Hydro</i>	3250	1950	-	-	-
	<i>Thermal</i>	4000	2800	3710	-	-
4-players	<i>Nuc./Hydro</i>	2500	1200	795	795	-
	<i>Thermal</i>	3000	1800	2855	2855	-
5-players	<i>Nuc./Hydro</i>	2500	1200	530	530	530
	<i>Thermal</i>	3000	1800	1903	1903	1903

A competitive benchmark, where the same initial total capacity and stochastic demand are used, has also been established. This has been computed by pooling the capacities of all firms together, and solving a stochastic program where investments and outputs are chosen so that the discounted total consumer surplus less production and investment cost is maximized. As mentioned in section 3.3, the cost functions are chosen so that the sum of capacities of individual firms may be interpreted as the total industry capacity, and the sum of cost functions of individual firms as the total industry cost function.

Figure 5 shows the market prices under the average demand growth path with one to five players and under perfect competition. The analysis clearly shows the advantage of a large number of players to reduce the impact of market power. Nevertheless, even with 5 players the effect of market power is notable, because the competitive benchmark indicates much lower prices. The impact of market power is more acute for peak load than base load periods.

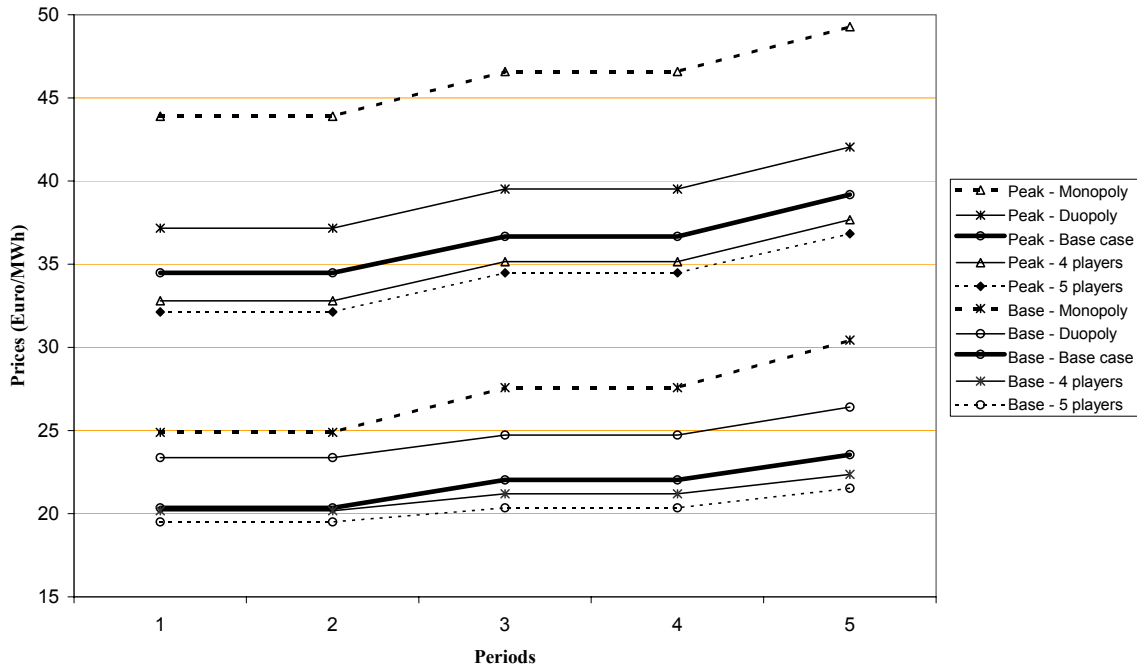

Figure 5 Base and peak load prices for different numbers of players and the competitive benchmark

As expected, the number of players intensifies competition and prices decrease as more players come to the market. There are no investments in the monopoly, duopoly and in the 4 players cases. However, some small investments are observed in the high growth scenario of the 3 and 5 players cases (respectively 66 MW and 8.1 MW). This result is due to the fact that in these two cases some players have lower initial capacities, relatively to the others. It is therefore optimal for them to increase it. Indeed, table 5 shows that in the 4-players case, the capacities of all players are more even. In the competitive benchmark, there is a much more notable investment of 1075 MW in the high growth scenario.

4.3 Investment cost

It would seem natural, at first sight, to have all the investments in the beginning of the game. The positive effects of investment would then be observed throughout the horizon. However, two elements give opposite incentives. The first one is the demand growth uncertainty, which threatens the profitability of investments in case of low growth. With such uncertainty, players tend to wait if the demand goes up before investing (firms acknowledge the *value of waiting*). The second element is the discounting of the cost and the depreciation of the capacity value. Therefore, it is not optimal to invest too early.

We do not observe significant new capacity addition with the base case investment cost parameters (see section 3.4). A relatively small amount (66 MW) of new capacity is added in period 4, in case of high growth. However, with lower investment costs some investment takes place. Table 6 shows the results. In the base case, player 3, who starts with a lower initial

capacity, makes the investment in period 4, only in the case of high demand growth. In the "low investment cost" case, player 3 invests more massively from the beginning, and continues in case of demand growth. Players 1 and 2, starting with higher initial capacities, do not invest.

Table 6 Total investments (MW) in 3 demand growth paths in 3-players base case and competitive benchmark (in bold) - Various investment costs

	Demand growth path	Period				
		1	2	3	4	5
BASE CASE	<i>No growth</i>	-	-	-	-	-
	<i>Average</i>	-	-	-	-	-
	<i>High</i>	-	-	-	66 / 1075	-
Low Investment costs	<i>No growth</i>	11 / 823	-	-	- / 22	-
	<i>Average</i>	11 / 823	-	708 / 1521	- / 44	-
	<i>High</i>	11 / 823	790 / 1891	784 / 1860	819 / 2145	-

In the competitive benchmark, as the bold numbers of table 6 show, there is much more investment, especially in the low investment costs case. This illustrates that although the pattern of investment is similar in the welfare maximizing solution, the scope of investment differs enormously.

The impact of increased capacity on price is illustrated in figures 6 and 7. Especially during peak load, increased capacity leads to significant reductions in prices even in the three-player oligopoly. This stresses out the importance of abundant capacity to relieve customers from the exercise of market power.

The competitive benchmark further shows the impact of investment on prices, with even lower prices in the case of low investment costs. Especially during the peak load, the effect of investment on prices is remarkable. Even in the high growth scenario, the capacity investments keep the price close to the initial level.

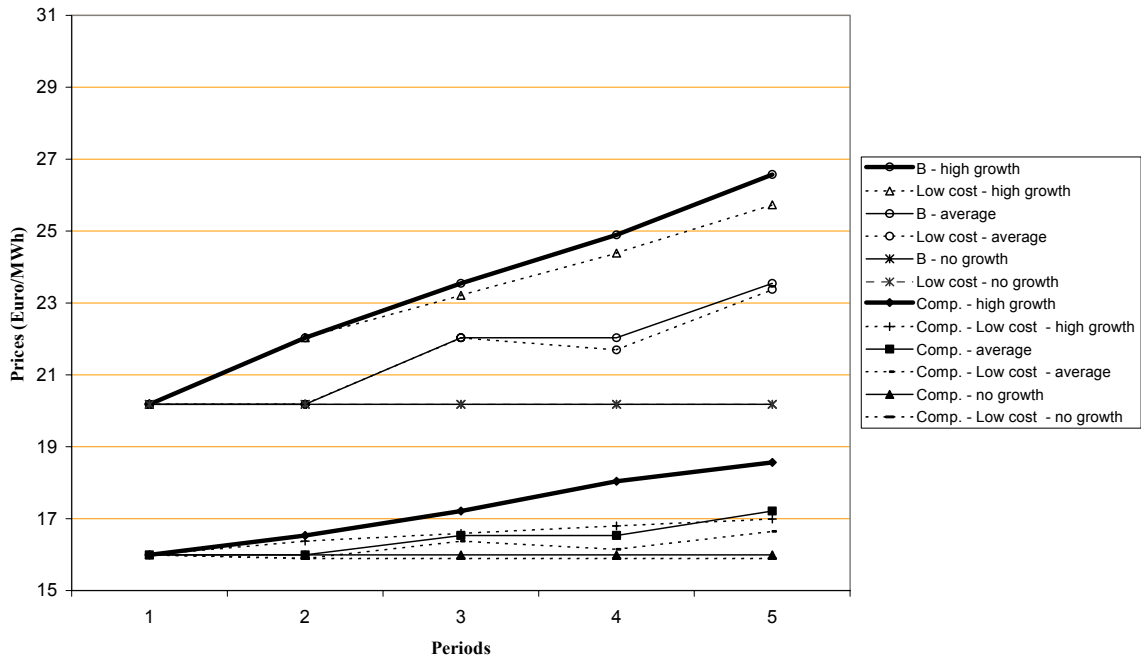

Figure 6 Base load prices for 3 demand growth paths in 3-players base case and competitive benchmark - Various investment costs

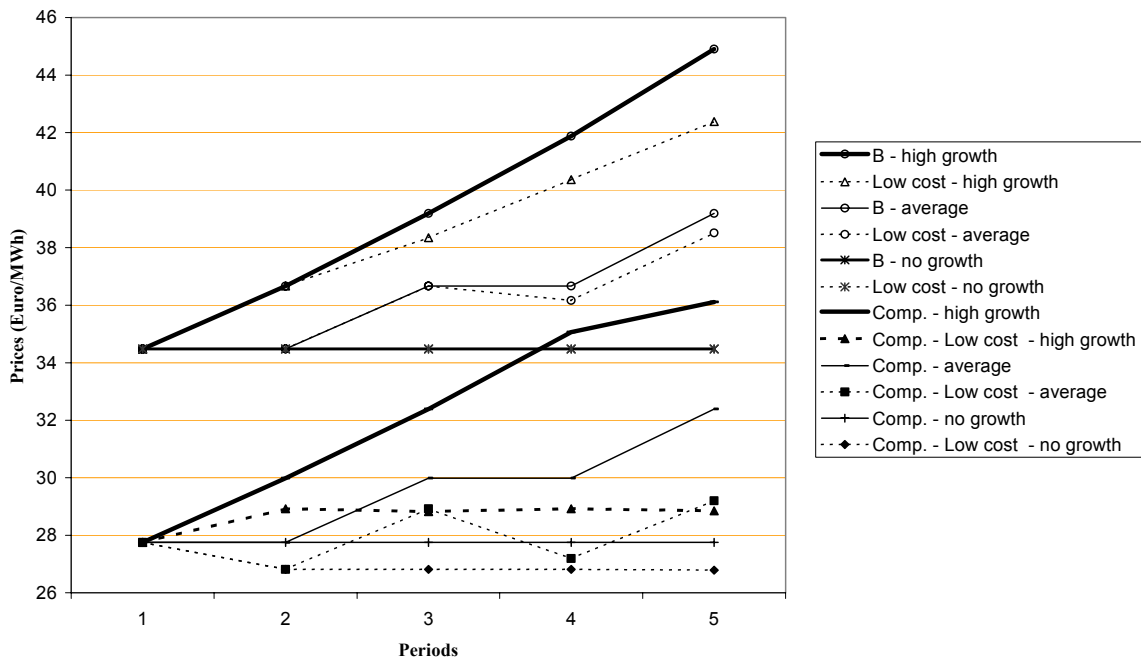

Figure 7 Peak load prices in 3 demand growth paths in 3-players base case and competitive benchmark - Various investment costs

As table 6 shows, investment is difficult to obtain in the oligopoly case. This is an issue of concern for many reasons. First, reliability problems could occur in peak periods if capacity is not maintained sufficiently high. Unregulated market players are not there to secure supply, but to ensure their maximum profit. Second, in an uncertain environment and with market power possibilities (especially if mergers reduce the total number of players), intentional *non*-investment could open the way to higher prices. This effect is even more intense in high demand growth scenarios, as illustrated by our results. These results also corroborate the findings of von der Fehr and Harbord (1995, 1997).

However, these results should be put in perspective with possible new entry and with supply from other countries. These two factors can alleviate the market power illustrated here. But although these external forces do exist, one should not forget that other countries face a similar situation, with limited investment possibilities. Furthermore, transmission constraints between countries limit exchanges. Concerning new entries in the domestic production market, barriers to entry, even if lower than a decade ago, still exist. Uncertainty and delay for building new units are also non-negligible. Therefore, before considering entry as the safeguard of competition, one should carefully assess its likelihood.

4.4 Elasticity of demand

We used empirical estimations of the elasticity of demand to guide our analysis. However, different estimates for different market segments and for short and long term periods can be found in the economic literature dealing with this topic. Also, different methodologies can be used and there is no consensus on the ideal one. They are well surveyed in Atkinson and Manning (1995). We base our choices on data from Bentzen and Engsted (1993), and Elkhafif (1992), because they are recent and conform to those in Atkinson and Manning (1995). Their estimation is between -0.4 and -0.6. Only for residential consumption, Bernard et al. (1996) found an elasticity near -0.9.

We assume here that base load demand is less elastic than peak load demand, because by definition base load consumption cannot be moved to another time. It is indeed the "base", omnipresent, consumption. See table 7 for the values used. The resulting prices are shown in figures 8 and 9. In the figures, A means low elasticity, B means base case, and C means high elasticity.

Table 7 Elasticities

	Base load period	Peak load period
A - Low elasticity	-0.4	-0.7
B - BASE CASE 3-players	-0.6	-0.9
C - High elasticity	-0.8	-1.1

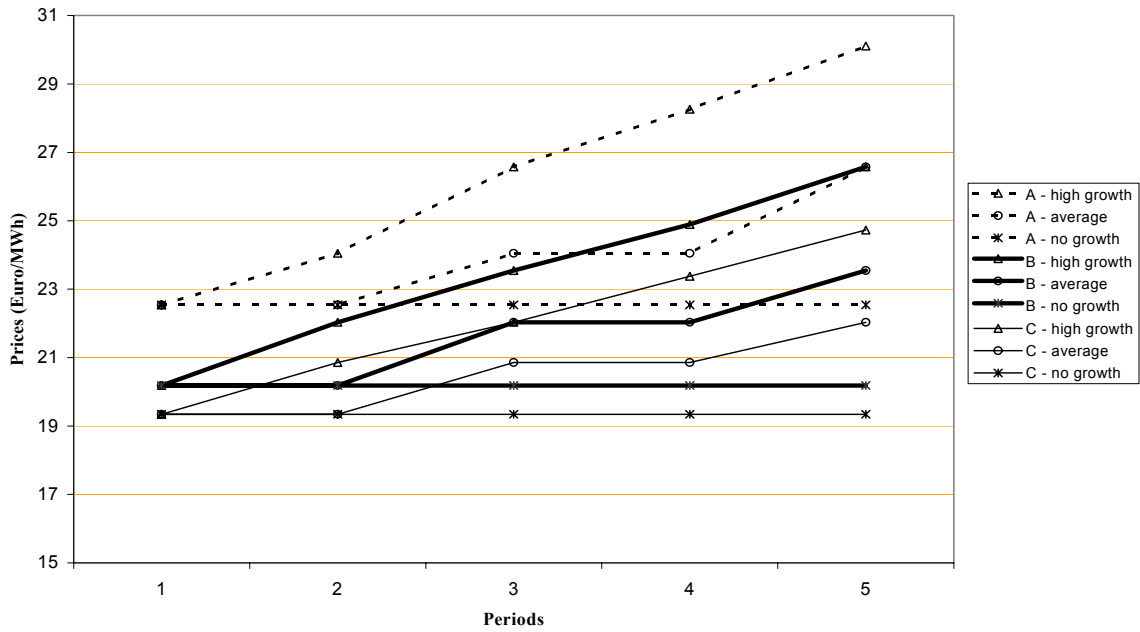

Figure 8 Base load prices in 3 demand growth paths - Various elasticity assumptions

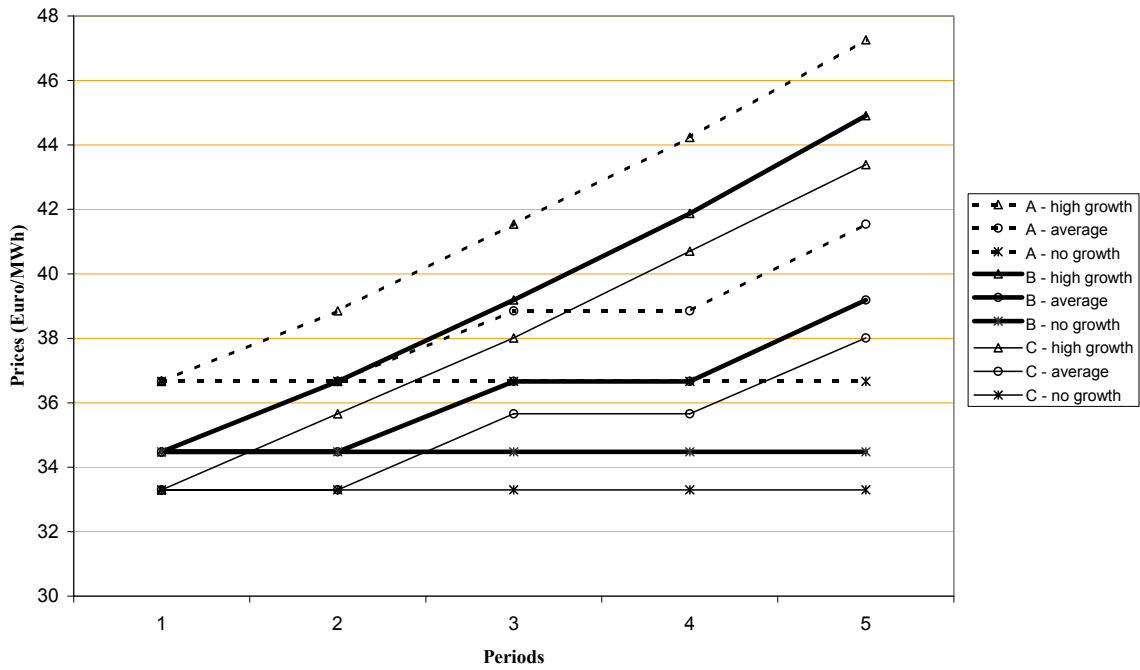

Figure 9 Peak load prices in 3 demand growth paths - Various elasticity assumptions

The change in elasticity has a smaller impact on the peak load price in relative terms than on the base load one. This is again due to the market power pressure present in the two situations. In peak load, as this pressure is already high, elasticity changes can not really relieve consumers from expensive electricity. Figures 8 and 9 illustrate the wider variations in prices in base load period than in the peak load one.

Concerning investment, player 3 invests moderately (19.9 MW) in the low elasticity case in period 4, in case of high growth. In case of high elasticity, his investment goes to 184.72 MW.

5 Conclusion

We constructed a dynamic-stochastic Nash-Cournot model for a simplified version of the Finnish electricity market. Base and peak load market segments and two groups of production technologies were characterized in a context of stochastic demand growth. Two algorithms were applied to compute the oligopolistic equilibrium under the S-adapted open loop information structure. Although lacking some characteristics of the closed-loop information structure, it still gives meaningful results. It gives insight on players' planning, and particularly on how they would react in the future in different demand growth scenarios. In this respect, our model offers a helpful description of the dynamic production-investment problem.

Market power was illustrated for different situations, as in many other contributions, but for one of the first times in a dynamic and stochastic context. The results of our model indicate that investments are difficult to obtain. Under different characterizations of the market (number of players, investment cost and price elasticity), investments were always very limited. The comparison to the competitive benchmark case further illustrated the significance of this issue. These results stress out a possible threat of high prices in the electricity sector, when large players and entry barriers are present. Indeed, strategic behavior coupled with uncertainty of demand growth can reduce investment compared to a "pre-deregulation" situation.

Further research could take the following directions. First, extensions to other neighboring countries would add in the relevance of such modeling, especially in Scandinavia where the electricity markets are becoming more and more integrated. This step would, however, require the integration of transmission issues, which constitutes an important aspect of the electricity business between countries. There is no lack of modeling challenges in the economics of electricity transmission. A third important research avenue would be to investigate the relations and differences of the S-adapted open-loop and feedback information structures. Assessing more formally whether or not feedback solutions conflict with S-adapted open loop ones in this context is a challenging goal.

Acknowledgments

Thanks are due to many readers of an earlier version and to two anonymous referees for their precious comments. We also want to thank Georges Zaccour (GERAD, École des Hautes Études Commerciales de Montréal) and Raimo Hämäläinen (Systems Analysis Laboratory, Helsinki University of Technology). Financial support from the Nordic Energy Research and IVO foundation is gratefully acknowledged.

References

- Andersson B. and Bergman L. (1995). "Market Structure and the Price of Electricity: An Ex ante Analysis of the Deregulated Swedish Electricity Market," *The Energy Journal* 16 (2).
- Andersson B. and Håse E. (1997). "Power Production and the Price of Electricity: an Analysis of a Phase-out of Swedish Nuclear Power," *Energy Policy* 25 (13), 1051-1064.
- Atkinson J. and Manning N. (1995). "A Survey of International Energy Elasticities." In Barker T., Ekins P. and Johnstone N. (eds.), *Global Warming and Energy Demand*. London: Routledge.
- Barker T., Ekins P. and Johnstone N. (1995). (eds.), *Global Warming and Energy Demand*. London: Routledge.
- Basar T. and Olsder G.J. (1995). *Dynamic Noncooperative Games*. 2nd edition. New York: Academic Press.
- Bentzen J. and Engsted T. (1993). "Short and Long-run Elasticities in Energy Demand: A Cointegration Approach," *Energy Economics* 9-16.
- Bernard J.-T., Bolduc D. and Bélanger D. (1996). "Québec Residential Electricity Demand: a Microeconomic Approach," *Canadian Journal of Economics/Revue canadienne d'économie* 29 (1), 92-113.
- Bertsekas D.P. and Tsitsiklis J.N. (1989). *Parallel and Distributed Computation: Numerical Methods*. Englewood Cliffs: Prentice-Hall.
- Bolle F. (1992). "Supply Function Equilibria and the Danger of Tacit Collusion: The Case of Spot Markets for Electricity," *Energy Economics* 14 (2), 94-102.
- Borenstein S., Bushnell J. and Knittel C. (1999). "Market Power in Electricity Markets: Beyond Concentration Measures," *The Energy Journal* 20 (4).
- Confederation of Finnish Industry and Employers/Finland Promotion Board (1998). "Neste and Ivo Merge into Largest Energy Group in Nordic Countries," *Finnfacts* March.
- Confederation of Finnish Industry and Employers (1998). *Teollisuuden Energiakatsaus 1/98*. In Finnish.
- Dafermos S. and Nagurney A. (1987). "Oligopolistic and Competitive Behavior of Spatially Separated Markets," *Regional Science and Urban Economics* 17, 245-254.
- De Wolf, D. and Smeers, Y. (1997). "A Stochastic Version of a Stackelberg-Nash-Cournot Equilibrium Model," *Management Science* 43 (2), 190-197.
- Elkhafif M.A.T. (1992). "Estimating Disaggregated Price Elasticities in Industrial Energy Demand," *The Energy Journal* 13 (4), 209-217.
- Finnish Energy Industry Federation (FINERGY) and Finnish Electricity Association (SENER) (1997). *E.L.E.C.T.R.I.C.I.T.Y. in Finland: Generation - Consumption - Transmission – Market*. Brochure.
- Friedman J.W. (1977). *Oligopoly and the Theory of Game*. Amsterdam: North Holland.
- Friedman J.W. (1986). *Game Theory With Applications to Economics*. New York: Oxford University Press.

- Gilbert R.J. and Khan E. (eds.). (1996). *International Comparisons of Electricity Regulation*. Cambridge: Cambridge University Press.
- Green R.J. (1997). "Increasing Competition in the British Electricity Spot Market," *Journal of Industrial Economics* 44 (2), 205-216.
- Green R.J. and Newbery D.M. (1992). "Competition in the British Electricity Spot Market," *Journal of Political Economy* 100 (5), 929-953.
- Harker P.T. (1984). "A Variational Inequality Approach for the Determination of Oligopolistic Market Equilibrium," *Mathematical Programming* 30, 105-111.
- Harker P.T. and Pang J.-S. (1990). "Finite-Dimensional Variational Inequality and Nonlinear Complementary Problems: A Survey of Theory, Algorithms and Applications," *Mathematical Programming* 48, 161-220.
- Haurie A., Zaccour G., Legrand J. and Smeers Y. (1988). "Un modèle de Nash-Cournot stochastique et dynamique pour le marché du gaz." In Haurie A., Poirier A., Zaccour G., and Smeers Y. (eds.), *Modélisation et analyse des marchés du gaz naturel – Actes du colloque*. Montréal: HEC, GERAD, CETAI.
- Haurie A., Zaccour G. and Smeers Y. (1990). "Stochastic Equilibrium Programming for Dynamic Oligopolistic Markets," *Journal of Optimization Theory and Applications* 66 (2), 243-253.
- Hobbs B.F. (1986). "Network Models of Spatial Oligopoly with an Application to Deregulation of Electric Generation," *Operations Research* 34 (3), 395-409.
- Hobbs B.F. and Kelly K.A. (1992). "Using Game Theory to Analyze Electric Transmission Pricing Policies in the United States," *European Journal of Operational Research* 56, 154-171.
- International Energy Agency (1994). *Energy Policies of IEA Countries - 1993 Review*. Paris: OECD/OCDE.
- International Energy Agency (1996). *Energy Prices and Taxes - 3rd Quarter 1996*. Paris: OECD/OCDE.
- IVO (1997). *Annual Report 1996*. Helsinki: IVO.
- Kanudia A. and Loulou R. (1998). "Robust Responses to Climate Change Via Stochastic MARKAL: The Case of Québec," *European Journal of Operational Research* 106, 15-30.
- Klemperer P.D. and Meyer M.A. (1989). "Supply Function Equilibria in Oligopoly Under Uncertainty," *Econometrica* 75 (6), 1243-1277.
- Kinderlehrer D. and Stampaccia G. (1980). *An Introduction to Variational Inequalities and Their Applications*. New York: Academic Press.
- Marcotte P. (1983). "Quelques notes et résultats nouveaux sur le problème d'équilibre d'un oligopole," *R.A.I.R.O, Recherche opérationnelle / Operation Research* 18 (2), 147-171.
- Mathiesen L., Roland K. and Thonstad K. (1987). "The European Natural Gas Market: Degrees of Monopoly Power." In Golombeck R., M. Hoel and J. Vislie (eds.), *Natural Gas Markets and Contracts*. Amsterdam: North Holland.
- Ministry of Trade and Industry, Department of Energy (1997). *Network Pricing in the Finnish Electricity Supply Industry*. Publication B:173, Helsinki.

- Murphy F.H., Serali H.D. and Soyster A.L. (1982). "A Mathematical Programming Approach for Determining Oligopolistic Market Equilibrium," *Mathematical Programming* 24, 92-106.
- Nagurney A. (1988). "Algorithms for Oligopolistic Market Equilibrium Problems," *Regional Science and Urban Economics* 18, 425-445.
- Nagurney A. (1993). *Network Economics: A Variational Inequality Approach*. Dordrecht: Kluwer Academic Publishers.
- Nordel (1998). *Annual Statistics*. Web page, www.nordel.org.
- Pang J.S. and Chan D. (1982). "Iterative Methods for Variational and Complementary Problems," *Mathematical Programming* 24, 284-313.
- Pineau P.-O. and Hämäläinen R.P. (2000). "A Perspective on the Restructuring of the Finnish Electricity Market," *Energy Policy* 28 (3), 181-192.
- PVO (1997). *Annual Report 1996*. Helsinki: PVO.
- Rutherford T. (1993). "MILES: A Mixed Inequality and Non-Linear Equation Solver." In *GAMS - The Solver Manual*. Washington DC: GAMS Development Corporation.
- Salant S.W. (1982). "Imperfect Competition in the International Energy Market: A Computerized Nash-Cournot Model," *Operations Research* 30 (2), 252-280.
- Smeers Y. (1997). "Computable Equilibrium Models and the Restructuring of the European Electricity and Gas Markets," *The Energy Journal* 18 (4).
- von der Fehr N.-H.M. and Harbord D. (1995). "Capacity Investment and Long-Run Efficiency in Market-Based Electricity Industries." In Olsen O.J. (ed.), *Competition in the Electricity Supply Industry: Experience from Europe and the United States*. Copenhagen: DJOF publishing.
- von der Fehr N.-H.M. and Harbord D. (1997). "Capacity Investment and Competition in Decentralised Electricity Markets," *Memorandum from Department of Economics*, University of Oslo, No 27, November 1997.
- Younes Z. and Ilic M. (1998). "Generation Strategies for Gaming Transmission Constraints: Will the Deregulated Electric Power Market Be an Oligopoly?," *Proc. 31st Annual Hawaii International Conference on Systems Science*, 112-121.
- Zaccour G. (ed.) (1998). *Deregulation of Electric Utilities*. Boston: Kluwer Academic Publishers.